

An epitome of Soundking products supply chain

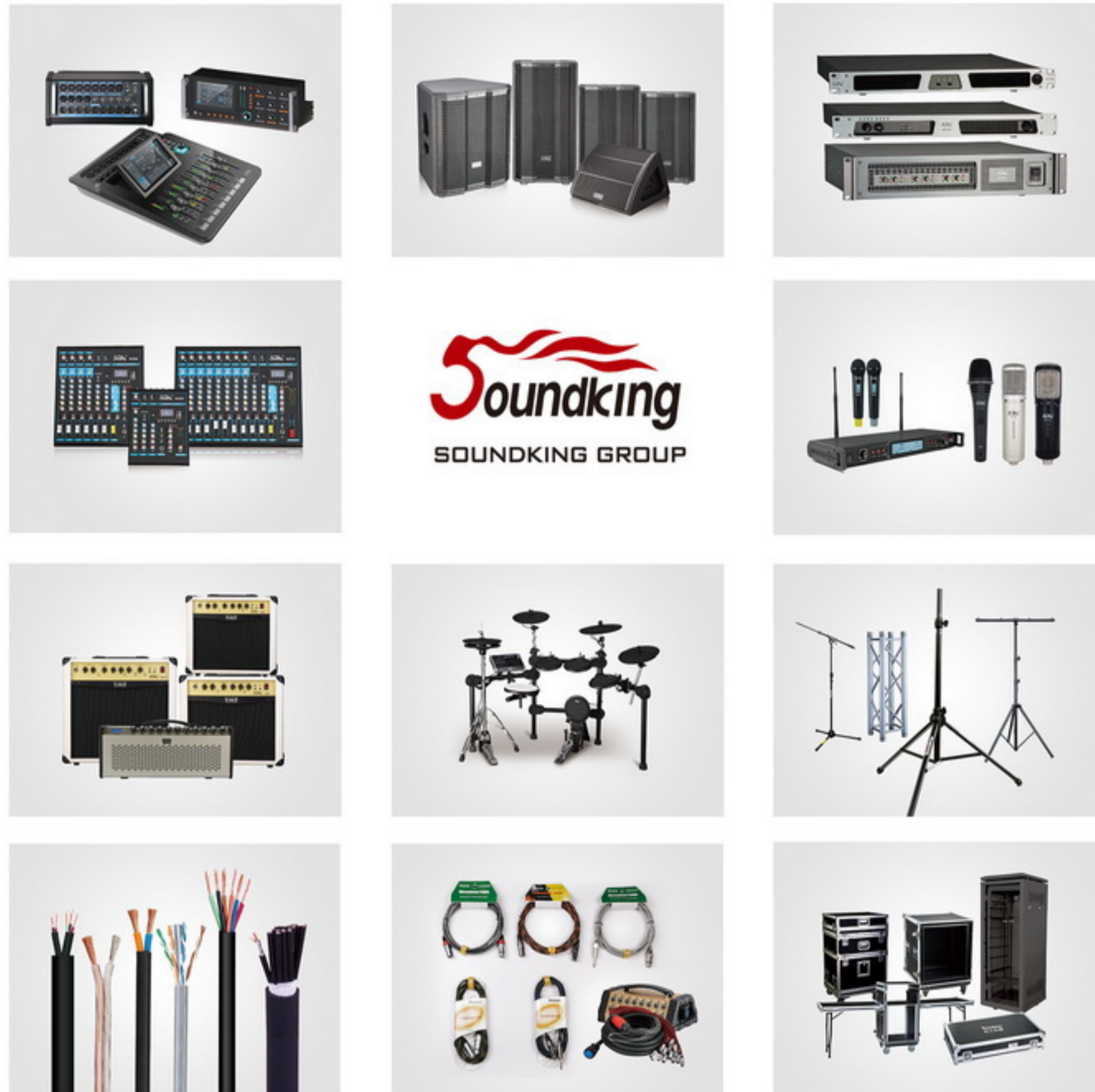

MUSIC AND LIGHTING STANDS

Speaker stand/Mic stand/Guitar stand/Keyboard stand

**OUR STANDS LEADING
THE TREND OF SOUND INDUSTRY**

www.soundking.com

Soundking Group (Soundking Electronics & Sound Co.,Ltd.)
Add:818# Chengxin Road Yinzhou Investment Industry Park, NingboChina Web: www.soundking.com
Email: sales@soundking.com Tel: +86-574 88235195 88237437 Fax: +86-574 88235763



2018 NEW

GLOBAL ONE STOP SUPPLIER OF PRO AUDIO & INSTRUMENT



COMPANY PROFILE

Soundking group was established in August, 1988 and it is a corporate group that dedicatedly engages in R&D, manufacturing, sale and international trade service of audio equipment, digital cinema system and related performing equipment. At present, Soundking's products cover 8 prime categories of pro audio, digital mixing console, digital cinema system, digital musical instrument, stage lighting, audio/video cable & connector, intelligent platform and so on, which totally come to over 4000 models of products.

Soundking always persists in revitalizing national industry and building national audio brand, well known as "National Enterprise Technical Center", "National Model Base of Cultural Industry", "National Key Enterprise of Culture Export", "National Post-doctoral Scientific Workstation", "Chinese Enterprise of Quality and Integrity", "National Key High-Tech Enterprise", "Chinese Model Enterprise of Export Quality and Safety", etc. Soundking is ranked the 30th among the 225 most famous pro audio and musical instrument suppliers in the world.

In 2010, Soundking has successfully played a role in Shanghai World Expo while it became the specified brand of audio equipment for China Pavilion and Theme Pavilion. In 2011, the group is the Global Partner of Speakers Systems of 2011 Xi'an International Horticultural Expo. For consecutive 3 years, Soundking won the title of "Quality Product" in domestic pro audio and power amplifier industry.

As a global one-stop pro audio and musical instrument manufacturing services provider, Soundking owns four world famous brands - Studiomaster (pro audio brand since 1976), CADAC (high-end mixing console brand since 1968), Carlsbro (musical instrument and loudspeaker brand since 1959), and PGS (American brand since 1998). Soundking focuses on the development of both domestic and overseas market, and adheres to the strategy of product and brand diversifying.

Besides, Soundking is also an internationalized enterprise who has set up R&D base in UK, USA, Germany, etc. More than 140 technical elites constitute the excellent R&D teams in China and abroad. Therefore, Soundking has completed the large scale indoor audio&light exhibition hall, Asian biggest full anechoic chamber, and Chinese first 15.1 DOLBY ATMOS Digital Cinema Experimental Base.

CONTENTS

Innovative Products

Microphone stands	01
Speaker stands	06
Keyboard stands	10
"x" keyboard stands	11
Music stands	13
Guitar stands	14
Lighting stands	21

Other Products

Microphone stands	23
Microphone stands and accessories	30
Gooseneck for microphone holders	32
Speaker stands	33
Speaker mount	37
"x" keyboard stands	38

Music stands	41
iPad holder	46
Keyboard bench	48
Rack stands	50
Guitar stands	52
Guitar foot stools & accessories	58
Audiovisual stands	58
Saxophone stands	59
Bags for stands	60
Mobile stage stands	61
Lighting stands	66

SD Series

- fold/unfold the labeled foot to move the mast tube, easy operation.
- Three feet locking the mast tube in a untraditional way.
- Concise contour; folding / unfolding mechanism.
- Unique user friendly design in a untraditional way; high intensity parts for reliable performance.

CHINA PATENT NO.: 2014204096920 2014103534462



NEW
No screw

VS



OLD
Have screw

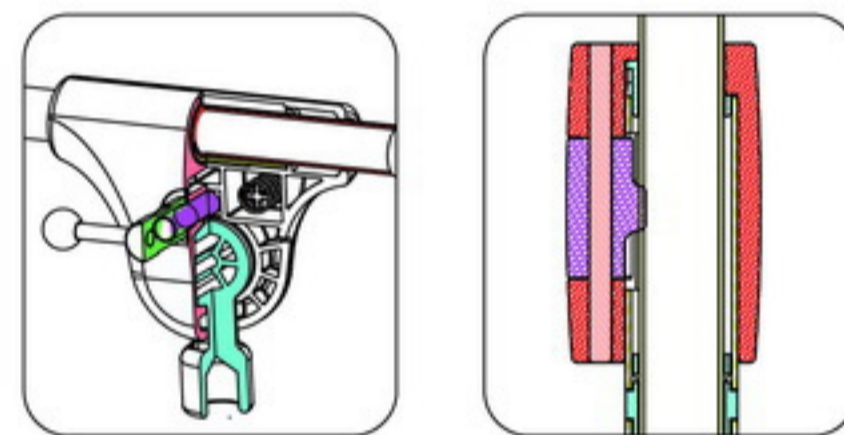

Height: 1000-1600mm
 Material: Steel
 Base Material: Metal
 Inner box: 95x95x1030(1pcs)
 Master Carton: 305x210x1050(6pcs)
 Weight: 2.5kg(Inner box/1pcs)

Mechanism Diagram

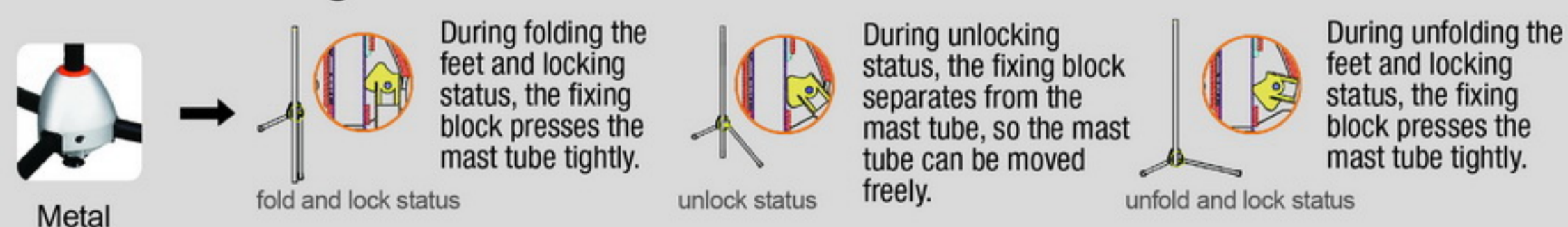

SD251
(Single-bar) **SD252**
(Double-bar)

Height: 1000-1600mm
 Material: Steel
 Base Material: Metal
 Inner box: 90x90x860(1pcs)
 Master Carton: 300x200x890(6pcs)
 Weight: 2.5kg(Inner box/1pcs)



SD261
(Single-bar) **SD262**
(Double-bar)

Height: 1000-1600mm
 Material: Steel
 Base Material: Metal
 Inner box: 90x90x860(1pcs)
 Master Carton: 300x200x890(6pcs)
 Weight: 2.5kg(Inner box/1pcs)



SD217
(Single-bar) **SD227**
(Double-bar)

Height: 1000-1600mm
 Material: steel
 Inner box: 95x95x1030 (1pcs)
 Master Carton: 305x210x1050 (6pcs)
 Weight: 2.5kg (inner box/1pcs)



SD218
(Single-bar) **SD228**
(Double-bar)

Height: 1000-1600mm
 Material: steel
 Inner box: 95x95x1170 (1pcs)
 Master Carton: 305x210x1195 (6pcs)
 Weight: 3kg (inner box/1pcs)



SD219
(Single-bar)
SD229
(Double-bar)

Height	1000-1600mm
Material	steel
Inner box	95×95×1030 (1pcs)
Master Carton	305×210×1050 (6pcs)
Weight	3kg (inner box/1pcs)



SD271

Height:	1000-1600mm
Material:	Steel
Base Material:	Metal
Inner box:	90×90×850(1pcs)
Master Carton:	295×200×870(6pcs)
Weight:	1.8kg(Inner box/1pcs)



SD216

Height	450mm
Material	steel
Inner box	95×95×515 (1pcs)
Master Carton	305×210×540 (6pcs)
Weight	2kg (inner box/1pcs)



SD226

Height	550-800mm
Material	steel
Inner box	95×95×600 (1pcs)
Master Carton	305×210×620 (6pcs)
Weight	2kg (inner box/1pcs)



SD201

Height	800mm
Material	steel
Inner box	80×70×810 (1pcs)
Master Carton	235×180×830 (6pcs)
Weight	0.7kg (inner box/1pcs)



SD202

Height	500-800mm
Material	steel
Inner box	80×70×540 (1pcs)
Master Carton	235×180×560 (6pcs)
Weight	0.7kg (inner box/1pcs)



SD281

Height:	1000-1600mm
Material:	Steel
Base Material:	Metal
Inner box:	90×90×850(1pcs)
Master Carton:	295×200×870(6pcs)
Weight:	1.8kg(Inner box/1pcs)



SG206

Adjustment Range	Φ15-Φ30mm
Inner box	95×95×170 (1pcs)
Master Carton	305×210×365 (20pcs)
Weight	0.5kg



SD231

Height	1100-1650mm
Material	steel
Inner box	100×100×1000 (1pcs)
Master Carton	220×320×1020 (6pcs)
Weight	2kg(inner box/1pcs)

SD205

Height: 900-1500mm
 Material: Steel
 Base Material: Metal
 Inner box: 90x90x850(1pcs)
 Master Carton: 295x200x870(6pcs)
 Weight: 1.8kg(inner box/1pcs)

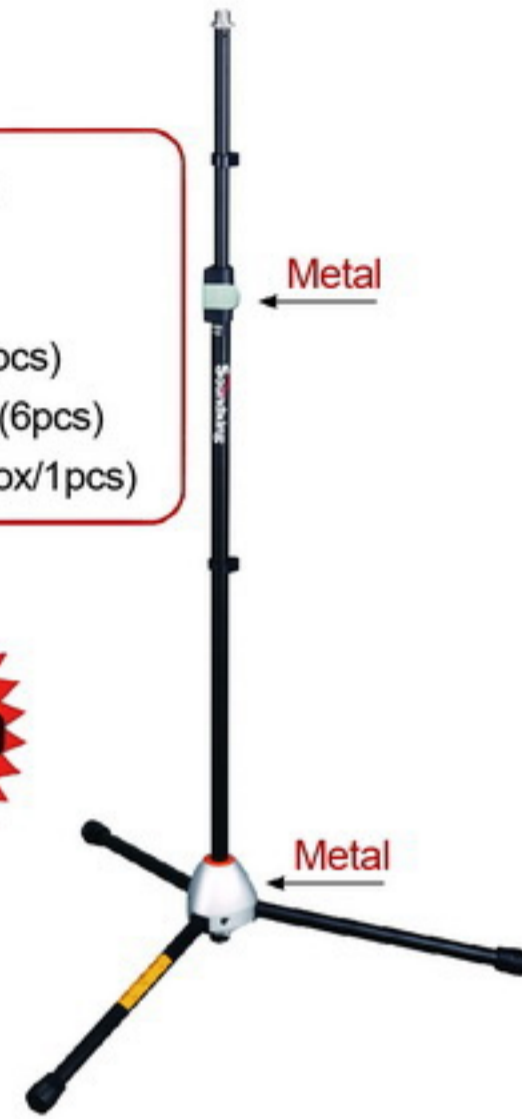

PATENTED

SD207

Height: 900-1500mm
 Material: steel
 Inner box: 90x90x850 (1pcs)
 Master Carton: 295x200x870 (6pcs)
 Weight: 1.5kg (inner box/1pcs)



PATENTED

SD208

Height: 1020-1620mm
 Material: steel
 Inner box: 90x90x1000 (1pcs)
 Master Carton: 295x200x1020 (6pcs)
 Weight: 2kg (inner box/1pcs)



PATENTED

SD209

Height: 900-1500mm
 Material: steel
 Inner box: 90x90x850 (1pcs)
 Master Carton: 295x200x870 (6pcs)
 Weight: 2kg (inner box/1pcs)



PATENTED



SB307
Air-cushion Lifting Speaker Stand

Specification:
 Height: 1100-1800mm
 Load capacity:50kg
 Material:aluminum alloy
 Inner box:135x125x1075mm (1pcs)
 Master Carton:290x270x1100mm (4pcs)

Patent NO.: #2013208330689 2013208611907

Dual-block mechanism holding telescopic tube for reliable operation; without the need of safety pin. Easy to adjust the height of speaker cabinet;



SB308
Air-cushion Heavy Lifting Speaker Stand

Specification:
 Height: 1100-1800mm
 Load capacity:60kg
 Material:aluminum alloy
 Inner box:130x130x1070mm (1pcs)
 Master Carton:280x280x1095mm (4pcs)

Patent NO.: #2013208330689 2013208611907

A: Dual-block mechanism holding telescopic tube for reliable operation; without the need of safety pin. Easy to adjust the height of speaker cabinet.

B: Air cushion mechanism to prevent from the speaker cabinet falling quickly and meanwhile ensure the safe operation;

PATENTED

SB309
Pneumatic Lifting Speaker Stands

Specification:
Height: 1100-1800mm
Load capacity:60kg
Material:aluminum alloy
Inner box:130x130x1130mm (1pcs)
Master Carton:280x280x1155mm (4pcs)

Patent NO.: #2013208330689 2013208611907

A:New locking mechanism for reliable safe operation; without the need of safety pin; Easy to adjust the height of the speaker cabinet by one hand.
B:Air cushion spring mechanism to prevent from the speaker cabinet falling quickly and make easy lifting and meanwhile ensure the safe operation;



PATENTED

SB500
Speaker Stand

All designed with rivet connection, no screw, not falling

Specification:
Height: 1040-1720mm
Load capacity:45kg
Material:Steel
Inner box:130x120x970mm (1pcs)
Master Carton:380x280x995mm (6pcs)
Weight:3.8Kg/1pcs

Patent NO.: #2013208330689 2013208611907

Dual-block mechanism holding telescopic tube for reliable operation; without the need of safety pin. Easy to adjust the height of speaker cabinet.



PATENTED

SB308L
Extra Long Air-cushion Speaker Stands

Specification:
Height: 1320-2200mm
Load capacity:60kg
Material:aluminum alloy
Inner box:130x130x1330mm (1pcs)
Master Carton:280x280x1360mm (4pcs)

Patent NO.: #2013208330689 2013208611907

A: Dual-block mechanism holding telescopic tube for reliable operation; without the need of safety pin. Easy to adjust the height of speaker cabinet.
B: Air cushion mechanism to prevent from the speaker cabinet falling quickly and meanwhile ensure the safe operation;

SB400

Height	1100-1680mm
Material	steel
Inner box	130x120x970 (1pcs)
Master Carton	380x280x995 (6pcs)
Weight	3.5kg (inner box/1pcs)

SB401

Height	1100-1680mm
Material	aluminum alloy
Inner box	125x125x1150 (1pcs)
Master Carton	400x270x1175 (6pcs)
Weight	3kg (inner box/1pcs)



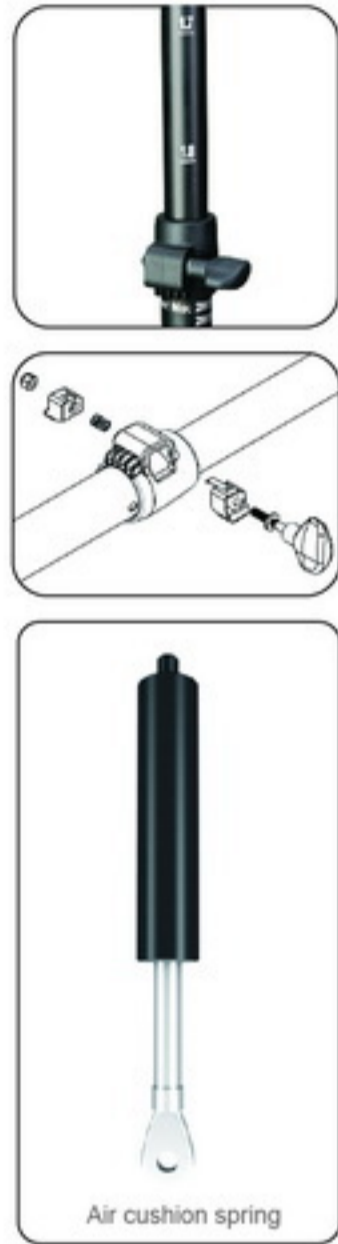

**SB310/SB311
Pneumatic Speaker Stand**

Specification:
 Height: 800-1340mm
 Load capacity: 50kg
 Material: aluminum alloy
 Inner box: 95x75x860mm (1pcs)
 Master Carton: 440x365x915mm (8pcs)
Patent NO.: #2013208330689



SB311



DC016



**SB312
Speaker Stand**

Specification:
 Height: 860-1260mm
 Load capacity: 50kg
 Material: iron
 Inner box: 95x75x860mm (1pcs)
 Master Carton: 600x190x915mm (10pcs)
Patent NO.: #2013208330689



**SB313
Speaker Stand**

Specification:
 Height: 880-1300mm
 Load capacity: 50kg
 Material: iron
 Inner box: 95x75x770mm (1pcs)
 Master Carton: 600x190x825mm (10pcs)
Patent NO.: #2013208330689



DC016

Features:

- Foldable and compact but solid structure;
- Supporting arms of adjustable height;
- 6063T-6 Aluminum for the mast;
- A360 Aluminum for connection parts; plastic wire clip.

Application:

suitable for various keyboards

Patent NO.:

#201320189766.X



Accessory:



Selection of color:



SK102

Specification:

Height(unfolded): 1245mm
 Folded dimension: 155x135x1350mm
 Self weight: 6kg

Adjustable height

Upper layer: 900-1100mm
 Lower layer: 680-880mm
 Inner carton: 330x290x1380mm(4pcs)
 Feet (unfolded): 520x880mm

Load capacity

Upper layer: 20kg
 Lower layer: 40kg

SF Series

- Height can be adjusted freely. After the wrench locked tightly, the stand can be opened directly.
- Scale helps to adjust the height.
- Clip can hold the disassembled horizontal bar.
- Elegant contour; less welding.

CHINA PATENT NO.: 2014204392500 2014103848915



SF507

Height	620-920mm
Arm length	Φ25 x 335mm
Material	steel
Inner box	125×120×980 (1pcs)
Master Carton	385×270×1010 (6pcs)
Weight	3.5kg (inner box/1pcs)
Load capacity	40kg



SF509

Height	620-920mm
Arm length	Φ25 x 335mm
Material	steel
Inner box	490×120×1020 (1pcs)
Master Carton	510×510×1050 (4pcs)
Weight	3.2kg (inner box/1pcs)
Load capacity	40kg



SF508

Height	620-920mm
Arm length	Φ30 x 350mm
Material	steel
Inner box	510×120×1030 (1pcs)
Master Carton	530×500×1050 (4pcs)
Weight	4.95kg (inner box/1pcs)
Load capacity	60kg



SF510

Height	620-920mm
Arm length	Φ30 x 350mm
Material	steel
Inner box	510×120×1020 (1pcs)
Master Carton	520×510×1000 (4pcs)
Weight	7kg (inner box/1pcs)
Load capacity	60kg



DF007-6

Height	470-990mm
Arm length	Φ25x 350mm
Material	steel
Inner box	110×110×990(1pcs)
Master Carton	235×235×1015 (4pcs)
Weight	5.0kg (inner box/1pcs)
Load capacity	60kg



DF029-6

Height	170-970mm
Arm length	Φ25x 400mm
Material	steel
Inner box	130×90×990(1pcs)
Master Carton	275×195×1015 (4pcs)
Weight	3.1kg (inner box/1pcs)
Load capacity	40kg

SF513

Height	620-920mm
Arm length	Φ25x 350mm
Material	steel
Inner box	125×120×975(1pcs)
Master Carton	265×255×1000 (4pcs)
Weight	4.8kg (inner box/1pcs)
Load capacity	60kg



DF032-6

Height	470-990mm
Arm length	Φ25x 400mm
Material	steel
Inner box	130×90×990(1pcs)
Master Carton	275×195×1015 (4pcs)
Weight	5.0kg (inner box/1pcs)
Load capacity	60kg



DF008-6

Height	470-980mm
Arm length	Φ25x 350mm
Material	steel
Inner box	110×110×990(1pcs)
Master Carton	235×235×1015 (4pcs)
Weight	3.3kg (inner box/1pcs)
Load capacity	40kg

PATENTED

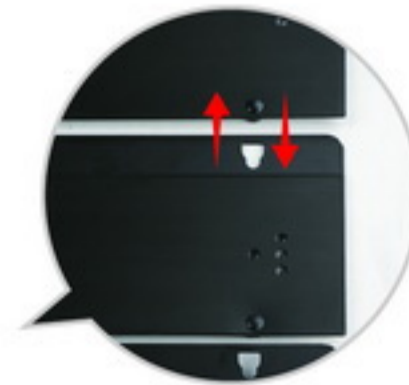

Convenient to dismantle,
easy to carry

SF629

Height	800-1300mm
Board dimension	480*336
Board material	aluminum
Weight	2kg
Inner box	150*100*600
Master Carton	320*220*630(4PCS)

PATENTED

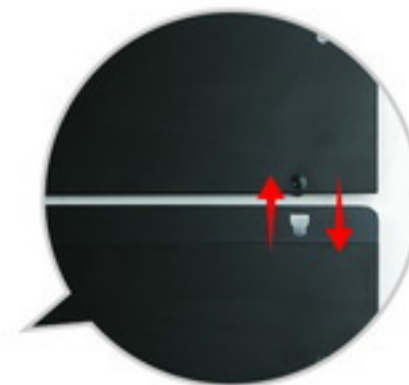

Convenient to dismantle,
easy to carry

SF629A

Height	800-1300mm
Board dimension	480*336
Board material	aluminum
Weight	1.85kg
Inner box	150*100*600
Master Carton	320*220*630(4PCS)

Floor Guitar Stand



PATENTED



Patent No.:2017203840568

SG721

Mast tube	φ25
Telescopic tube	φ19
Inner box	115x115x590mm
Height adjusted	450-1160mm
Master Carton	365x245x610mm(6pcs)
Weight	1.3kg

Optional:



Fold the guitar stand for smaller size.



Storage bag for guitar stand



New stand



Old stand



VS



SG722

Height	800-1200mm
Inner box	160x115x820mm
Master Carton	500x245x840mm(6pcs)
Load capacity	20kg
Weight	3kg



SF629DG

Height	850-1700mm
Arm Length	530-910mm
Base	Plastic
Weight	2.2KG
Inner box	100*100*600
Master Carton	320*220*630(6PCS)



SG723

Height	800-1200mm
Inner box	165x145x820mm
Master Carton	515x305x840mm(6pcs)
Load capacity	20kg
Weight	4kg



New stand



Guitar self-lock mechanism, simpler structure, lower costs of use, easier assembly.

VS

Old stand



Complex self-lock mechanism, excess parts, lower assembly efficiency, higher costs of use.

Wall-mounted Guitar Stand



SG720

Master Carton:
525x345x340mm(40pcs)



SG720A

Master Carton:
550x420x375mm(40pcs)



SG720B

Master Carton:
400x400x280mm(50pcs)



SG720C

Inner box:
110x100x350mm(1pcs)
Master Carton:
520x460x380mm(20pcs)



NEW
No screw

VS

OLD
Have screw

SG Series

Introduction:

The ergonomical design surpasses traditional way. Unique, simple, practical, compact, stable guitar stand with premium material;

Features:

- Dual-block-locking mechanism between feet and mast tube to reinforce stability. Move one foot to move the mast tube up and down; better than tradition locking;
- The bent tube and yoke can be assembled or disassembled quickly to save packing space and transportation cost.
- Elegant contour;



SG718 Guitar Stand

Specification:

Height:550-800mm
Material:Steel
Inner box:170x120x450(1pcs)
Master Carton:385x360x475(6pcs)
Weight:0.8kg(1pcs)

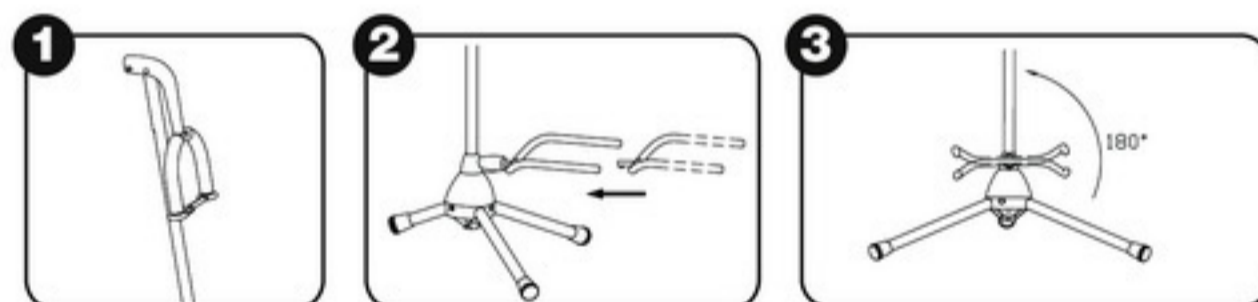

Insert the fork in

Insert the fork in, then rotate 180 degree
Dismantling: put the pin into the square hole, and take out the bent tube.

Mechanism Diagram



fold and lock status

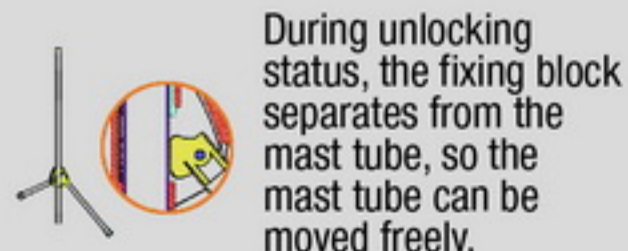

unlock status

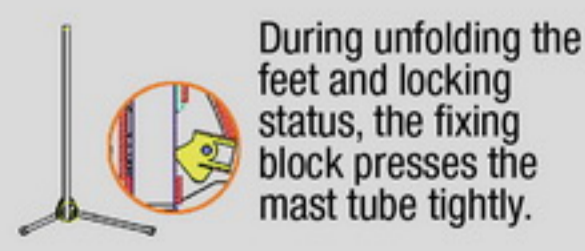

unfold and lock status



SG719 Guitar Stand

Specification:

Height:550-800mm
Material:Steel
Inner box:130x90x450(1pcs)
Master Carton:290x280x475(6pcs)
Weight:1kg(1pcs)

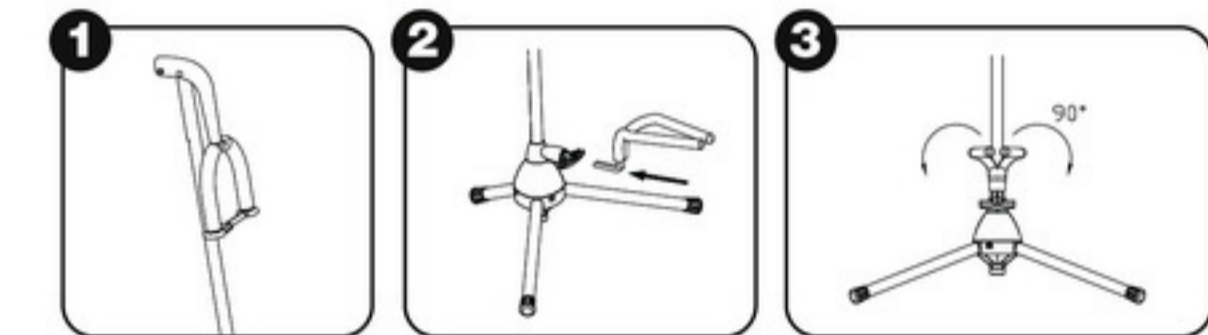

Put the supporting bars vertically and insert in. L

Put the supporting bars in and turn them 90 degree left and right.



SG708 Guitar Stand

Specification:

Height:800mm
Material:Steel
Inner box:170x120x450(1pcs)
Master Carton:385x360x475(6pcs)
Weight:1kg(1pcs)

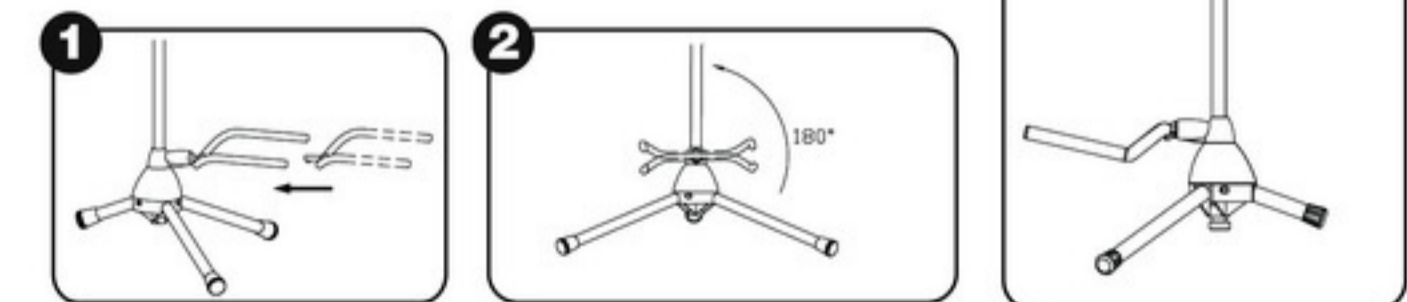

Insert the fork in

Insert the fork in, then rotate 180 degree
Dismantling: put the pin into the square hole, and take out the bent tube.

Dismantling: put the pin into the square hole, and take out the bent tube.



SG709 Guitar Stand

Specification:

Height:430-750mm
 Material:Steel
 Inner box:130x90x450(1pcs)
 Master Carton:295x280x475(6pcs)
 Weight:1kg(1pcs)

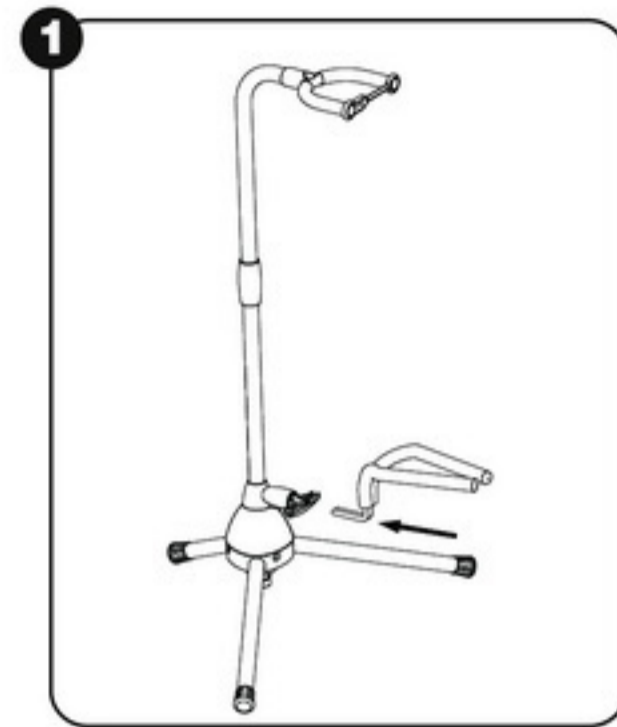

Put the supporting bars vertically and insert in. L

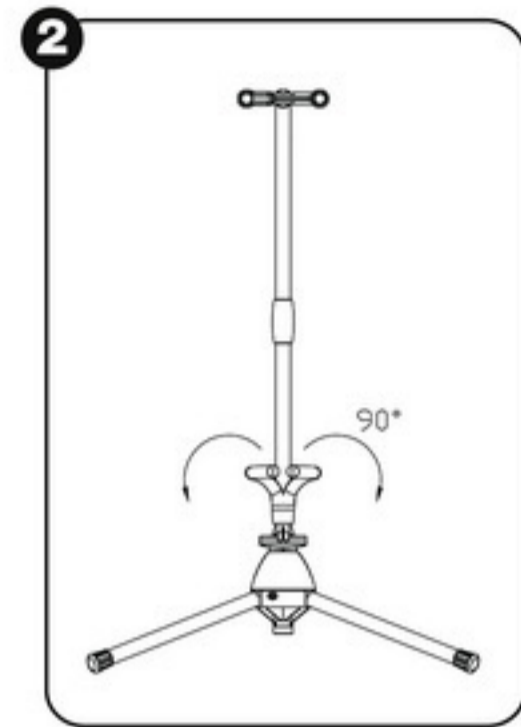

Put the supporting bars in and turn them 90 degree left and right.

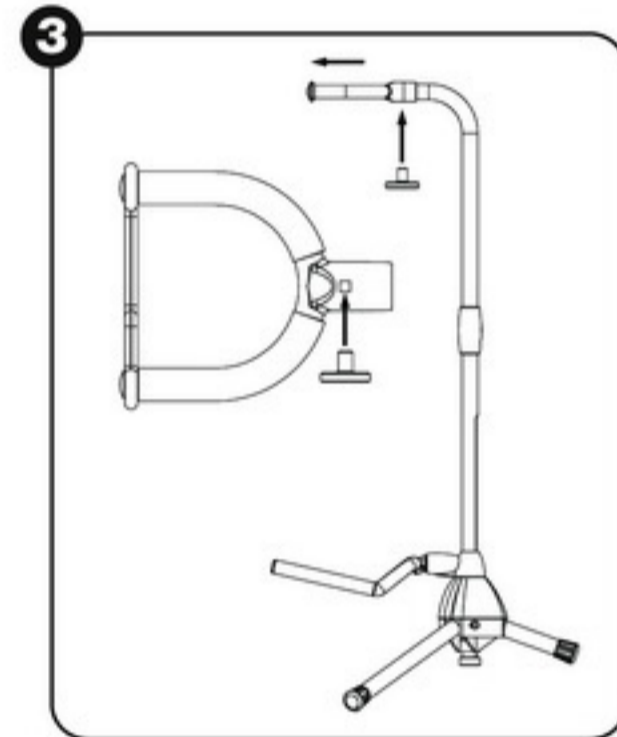

Dismantling: put the pin into the square hole, and take out the yoke.

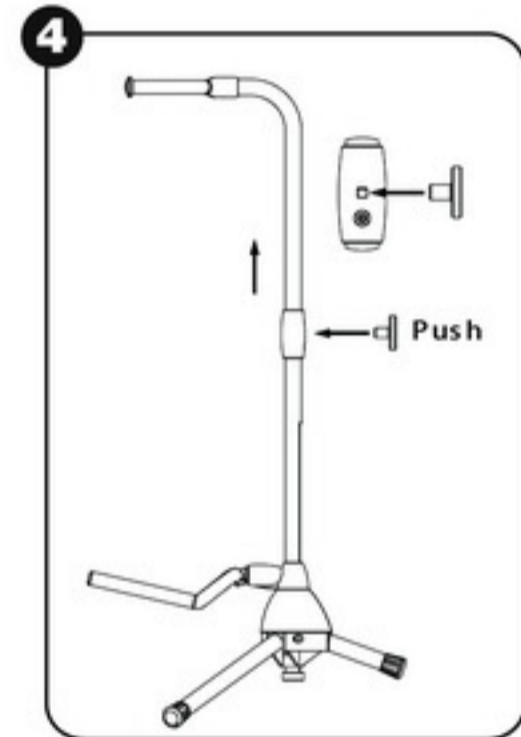

Dismantling: put the pin into the square hole, and take out the bent tube.



SG707 Guitar Stand

Specification:

Height:430mm
 Material:Steel
 Inner box:170x120x450(1pcs)
 Master Carton:385x360x475(6pcs)
 Weight:0.8kg(1pcs)

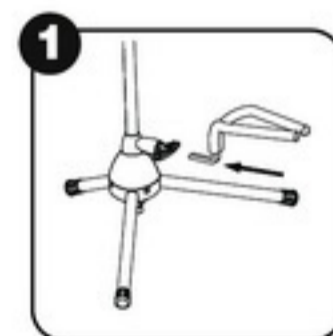

Put the supporting bars vertically and insert in. L

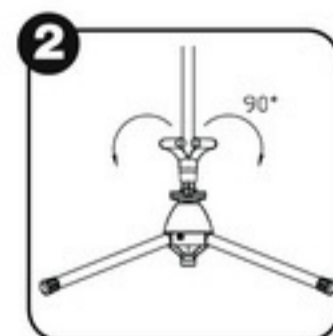

Put the supporting bars in and turn them 90 degree left and right.

SG70 Foldable Guitar Stand



Unfolded size: 320x80x460mm
 Folded size: 220x95x385mm

SG70S Foldable Guitar Stand



Unfolded size: 320x80x460mm
 Folded size: 220x95x385mm

SG70/SG70S

Specification:

Height: 440mm
 A-Frame Size: 210~345mm
 Weight: 1.8kg
 Inner box: 220x95x385mm
 Master carton: 405x240x415mm(4pcs)
 2/3 volume of the average package



SG80 Guitar Stand

Specification:

Material:Steel+EVA+PTE
 Height: 600-1200mm
 Inner box: 110x75x445mm
 Master Carton:465x240x405mm(1:10)
 Weight:1kg

Introduction:

- Light-weighted, small volume of package
- Green material; optimal structure to protect your guitar



SG60C Application

SG60C Guitar Stand

Specification:

Material:Steel+EVA+PTE
 Inner box: 105x75x355mm
 Master Carton:372x246x230mm(pcs)
 Weight:0.5kg

Introduction:

- Light-weighted, small volume of package
- Green material; optimal structure to protect your guitar
- Suitable for various guitars



PATENTED



SA107
Air-cushion Lighting Stands

Specification:

Height: 1900-3500mm
 Arm Length: Φ38x1220
 Material: Alu+Nyloon
 Inner box: 170x135x1310mm
 Master Carton: 360x300x1340mm
 Load Capacity: 50kg

Patent NO.:

#2013208330689 2013208611907

A: New locking mechanism for reliable safe operation; without the need of safety pin; Easy to adjust the height of the speaker cabinet by one hand.
 B: Air cushion mechanism to prevent from the lighting stands falling quickly and meanwhile ensure the safe operation;

SA108
Air-cushion Lighting Stands

Specification:

Height: 1900-3500mm
 Arm Length: Φ38x1220
 Material: Alu+Nyloon
 Inner box: 260x135x1310mm
 Master Carton: 540x295x1340mm
 Load Capacity: 50kg

Patent NO.:

#2013208330689 2013208611907

A: New locking mechanism for reliable safe operation; without the need of safety pin; Easy to adjust the height of the speaker cabinet by one hand.
 B: Air cushion mechanism to prevent from the lighting stands falling quickly and meanwhile ensure the safe operation;

PATENTED

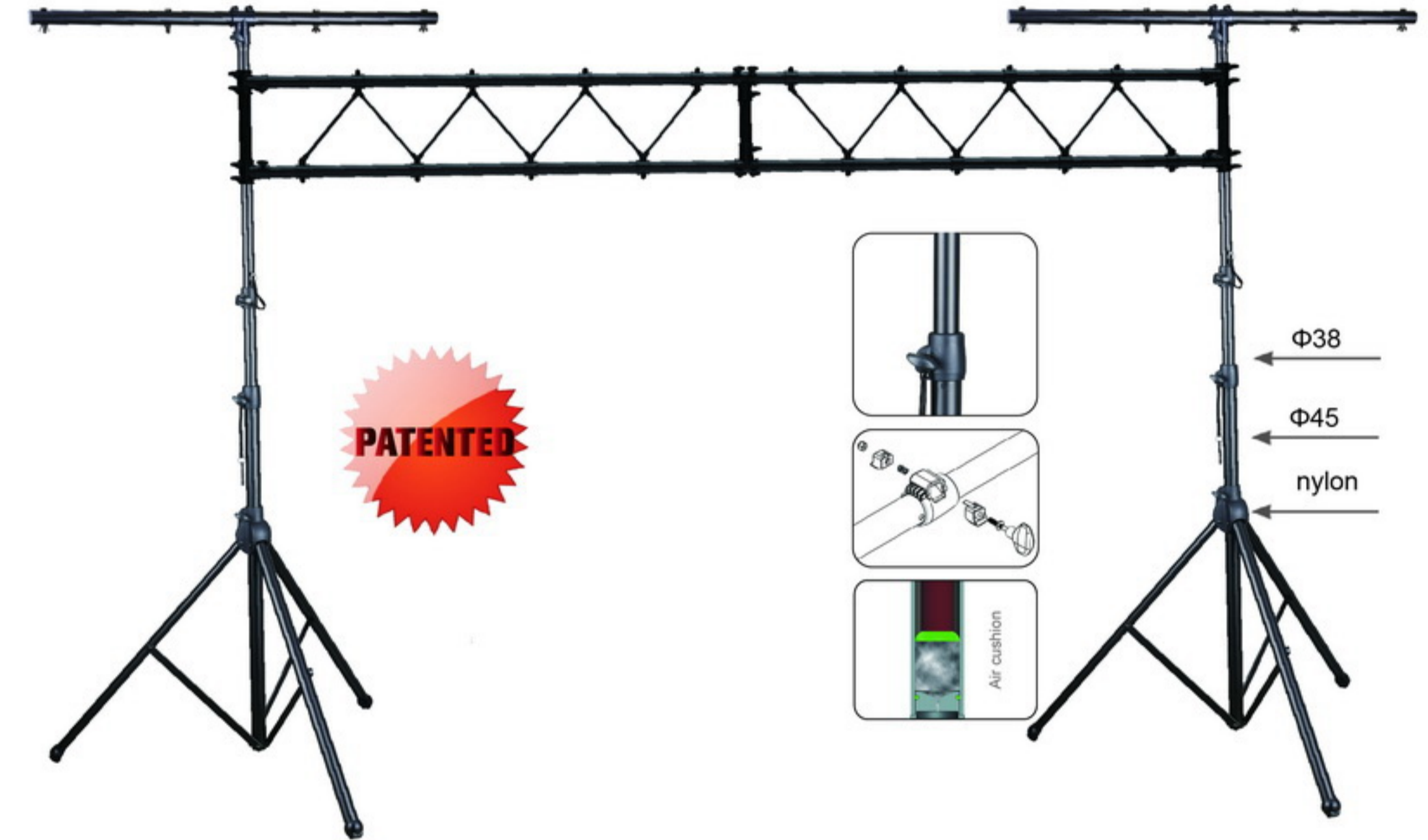



PATENTED

SA109
Air-cushion Lighting Stands

Specification:

Height: 1900-3500mm
 Arm Length: 1500-4000mm
 Material: Alu+Nyloon
 Master Carton: 370x240x1540mm(1set)
 Load Capacity: 100kg
 Shipping package: 350x90x1500mm(DA010-1)
 315x130x1310mm(SA102)

2x  Model No.SA107
 1x  Model No.DA010-1

Patent NO.:

#2013208330689 2013208611907

A: New locking mechanism for reliable safe operation; without the need of safety pin; Easy to adjust the height of the speaker cabinet by one hand.
 B: Air cushion mechanism to prevent from the lighting stands falling quickly and meanwhile ensure the safe operation;

DD089B

Adjustable Height	1000-1700 mm
Telescopic Boom	530-910 mm
Length	
Material	High Tensile Steel + Reinforced Nylon
Master Carton	290x200x1090mm(6pcs)
Weight	2kg(Inner box / 1pcs)

CHINA PATENT NO.: 200720191428.4



DD115

Height	1010-1730mm
Boom length	530-910mm
DIA.OF BASE	250mm
Inner box	95x90x1050mm(1pcs)
Master Carton	210x200x1080mm(4pcs)
Weight	2.7kg(Inner box / 1pcs)

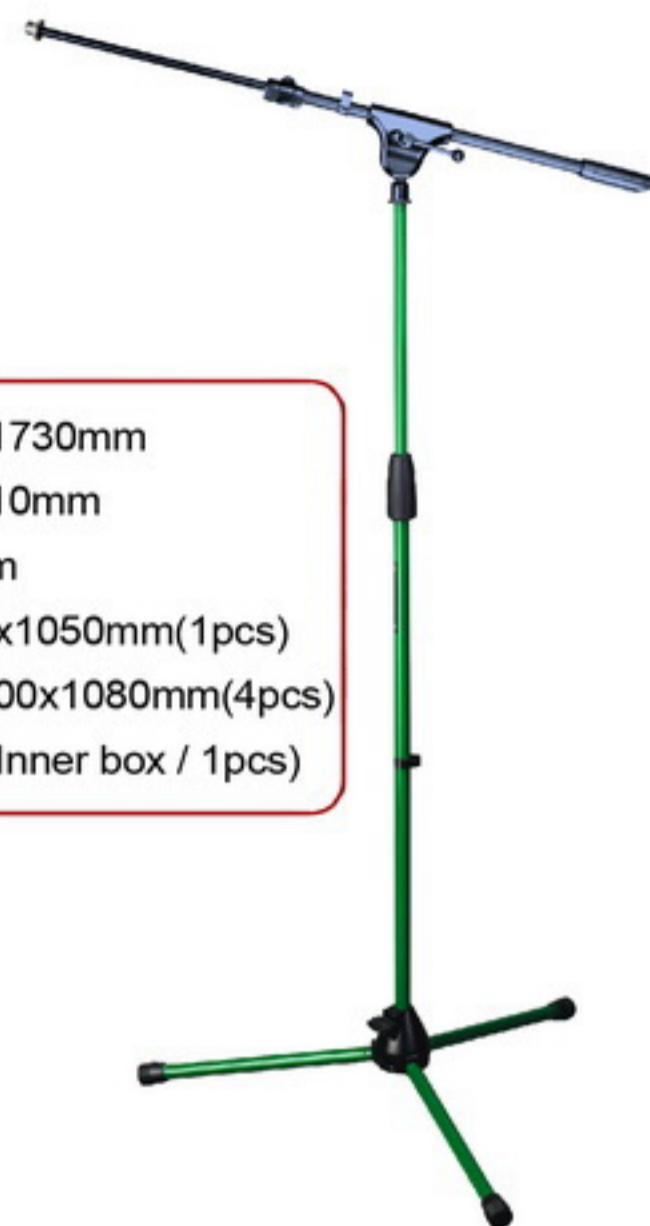

DD128 One-hand Microphone Stand Without Arm Boom

Adjustable height	1125-1675 mm
Base material	zinc alloy
Material	steel
Master Carton	320x220x1090mm(6pcs)



DD129 One-hand Microphone Stand With Arm Boom

Adjustable height	1050-1600 mm
Base material	Iron
Material	Steel
Base dia	250mm
Master Carton	310x270x1040mm(6pcs)

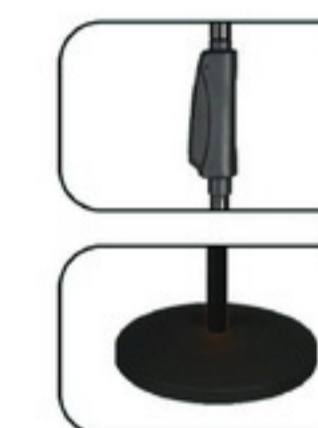

Economical

DD130

Height	1000-1700mm
Boom length	800mm
Inner box	100x100x910mm
Master Carton	320x220x940mm
Weight	1.8kg



DD126 One-hand Microphone Stand

Adjustable height	1150-1700 mm
Base material	zinc alloy
Material	steel
Base dia	530-910mm
Arm length	530-910mm
Inner box	100x100x1195mm
Master Carton	320x220x1225mm(6pcs)



DD090B

Height	1000-1700 mm
Arm Length	750 mm
Base	Plastic & Steel
Inner box	90x90x1030mm(1pcs)
Master Carton	290x200x1060mm(6pcs)
Weight	2.5kg(Inner box/1pcs)



DD002B/W

Height	980-1680mm
Arm Length	800mm
Base	Metal
Inner box	90x90x990mm(1pcs)
Master Carton	290x200x1010mm(6pcs)
Weight	3.2kg(Inner box / 1pcs)



DD003B/W

Height	1000-1760mm
Arm Length	530-910mm
Base	Metal
Inner box	90×90×860mm(1pcs)
Master Carton	290×200×890mm(6pcs)
Weight	2.5kg(Inner box / 1pcs)

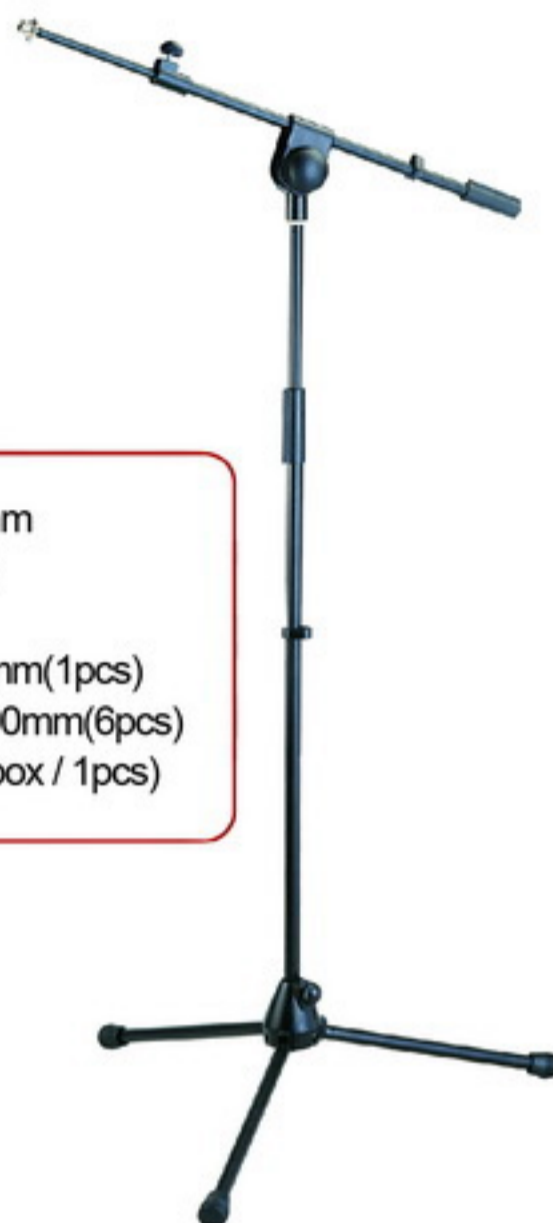

DD004B/W

Height	1000-1760mm
Arm Length	800mm
Base	Metal
Inner box	90×90×860mm(1pcs)
Master Carton	290×200×890mm(6pcs)
Weight	2.8kg(Inner box/1pcs)

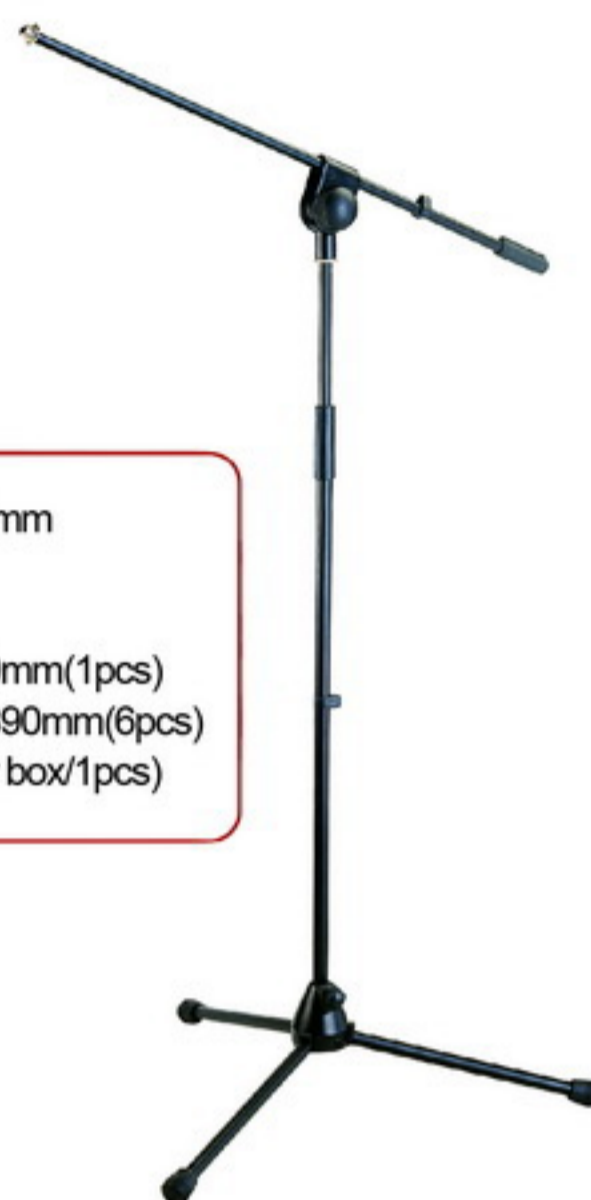

DD008B/W

Height	1010-1710mm
Arm Length	530-910mm
Base	Metal
Inner box	90×90×860mm(1pcs)
Master Carton	290×200×890mm(6pcs)
Weight	2.3kg(Inner box / 1pcs)



DD009B/W

Height	1100-1820mm
Arm Length	500mm
Base	Plastic
Inner box	90×90×860mm(1pcs)
Master Carton	290×200×890mm(6pcs)
Weight	2.3kg(Inner box/1pcs)

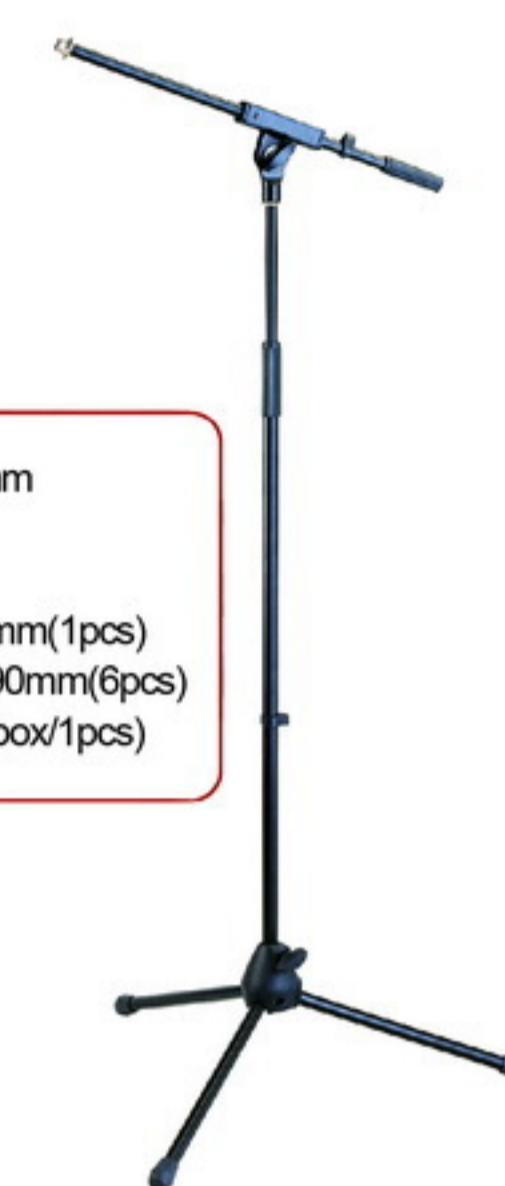

DD005B/W

Height	1000-1700mm
Arm Length	800mm
Base	Metal
Inner box	90×90×860mm(1pcs)
Master Carton	290×200×890mm(6pcs)
Weight	2.8kg(Inner box/1pcs)



DD007B/W

Height	1000-1700mm
Arm Length	800mm
Base	Metal
Inner box	90×90×860mm(1pcs)
Master Carton	290×200×890mm(6pcs)
Weight	3.2kg

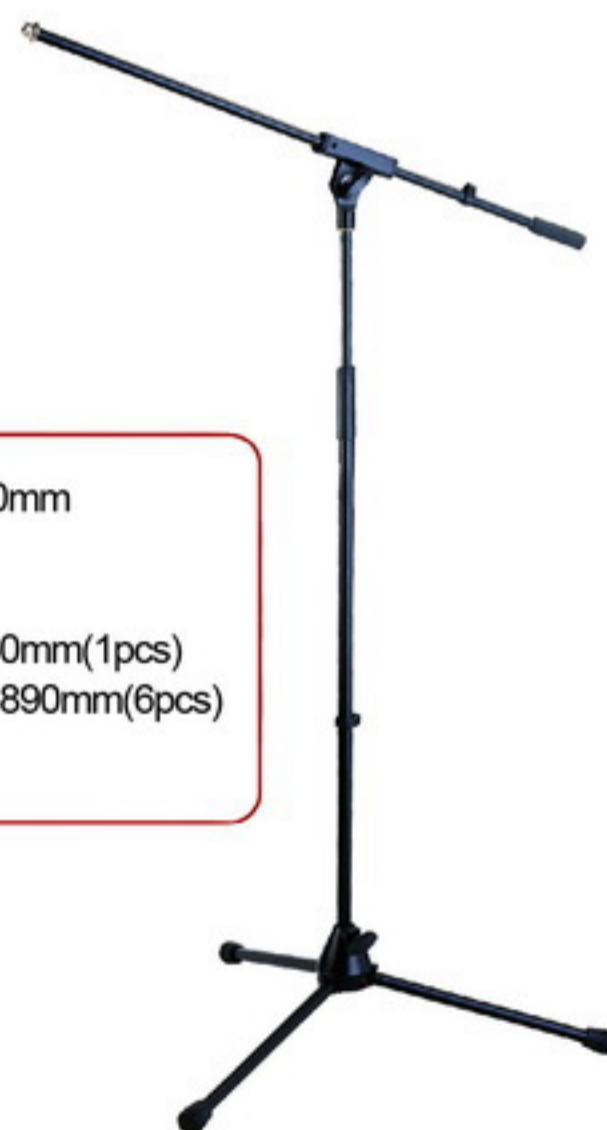

PLASTIC

PLASTIC

PLASTIC

DD061B/W

Height	850-1450mm
Arm Length	800mm
Base	Plastic
Inner box	90×90×860mm(1pcs)
Master Carton	300×200×890mm(6pcs)
Weight	2.1kg(Inner box / 1pcs)



DD085

Height	850-1800mm
Arm Length	800mm
Base	Heavy pan
Dia. of Base	250mm
Inner box	840×320×50×50mm(1pcs)
Master Carton	860×390×130mm(4pcs)
Weight	6kg(Inner box/1pcs)



1. Zinc Alloy
2. Plastic
All Different Optional
Spare Parts

MICROPHONE STANDS



DD032B/W

Height	470mm
Arm Length	500mm
Dia. of Base	180mm
Inner box	540×210×80×70mm(1pcs)
Master Carton	560×340×240mm(6pcs)
Weight	2.2kg(Inner box / 1pcs)



DD034B/W

Height	560-800mm
Arm Length	530-910mm
Base	Metal
Inner box	90×90×580mm(1pcs)
Master Carton	290×200×600mm(6pcs)
Weight	2.5kg(Inner box / 1pcs)



DD065B/W

Height	560-800mm
Arm Length	530-910mm
Base	Metal
Inner box	90×90×580mm(1pcs)
Master Carton	290×200×600mm(6pcs)
Weight	2.5kg(Inner box / 1pcs)



DD066B/W

Height	560-800mm
Arm Length	530-910mm
Base	Metal
Inner box	90×90×580mm(1pcs)
Master Carton	290×200×600mm(6pcs)
Weight	2.5kg(Inner box / 1pcs)



DD035B/W

Height:	540mm
Arm Length:	530-910mm
Base:	Metal
Shipping Package:	29x20x60cm(6pcs)



DD054B/W

Height:	540mm
Arm Length:	530-910mm
Base:	Metal
Shipping Package:	29x20x60cm(6pcs)

DD017B/W

Height	920-1620mm
Base	Metal
Inner box	90×90×860mm(1pcs)
Master Carton	290×200×890mm(6pcs)
Weight	2.3kg(Inner box / 1pcs)

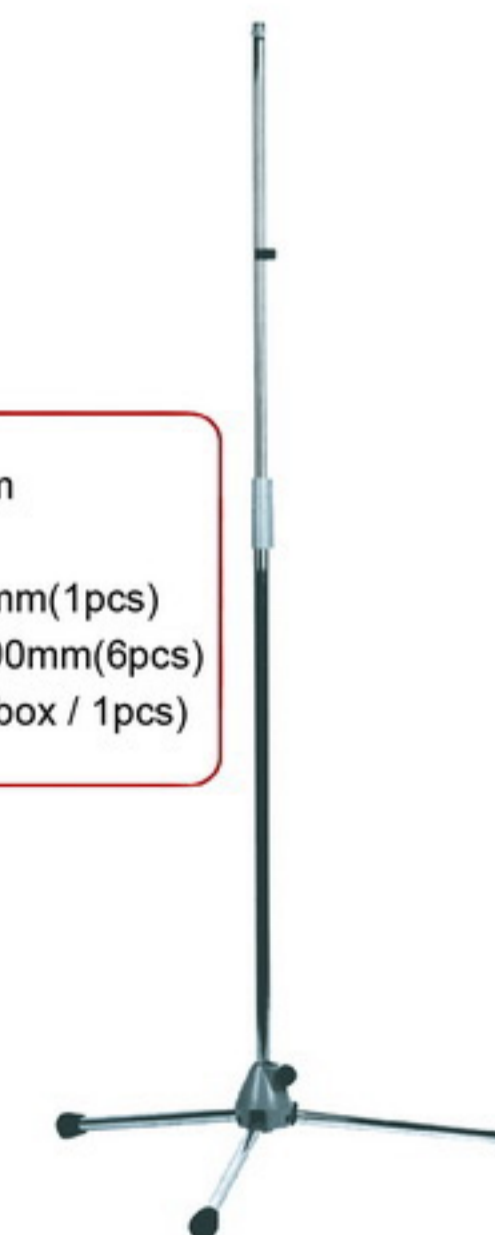

DD028B/W

Height	960-1880mm
Gooseneck	φ15×300mm
Dia. of Base	250mm
Inner box	840×320×50×50mm(1pcs)
Master Carton	860×390×130mm(4pcs)
Weight	5kg(Inner box / 1pcs)

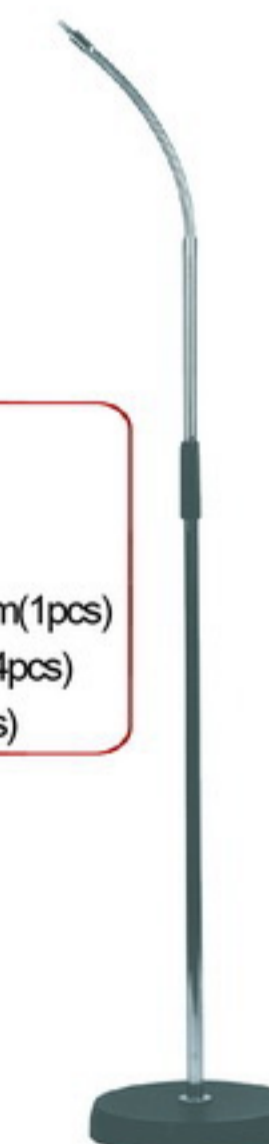

MICROPHONE STANDS

MICROPHONE STANDS

DD030B/W

Height	880-1580mm
Dia. of Base	250mm
Inner box	840×320×50×50mm(1pcs)
Master Carton	860×390×130mm(4pcs)
Weight	5kg(Inner box/ 1pcs)



DD049B/W

Height	855-1544mm
Dia. of Base	250mm
Inner box	840×320×50×50mm(1pcs)
Master Carton	860×390×130mm(4pcs)
Weight	5kg(Inner box / 1pcs)



DD069B/W

Height	370mm
Gooseneck	φ 15×300mm
Base	Steel
Inner box	565×175×75mm(1pcs)
Master Carton	750×430×700mm(100pcs)
Weight	1.9kg(Inner box / 1pcs)

DD077B/W

Master Carton 590×300×430mm(10pcs)



DD053B/W

Height	880-1580mm
Dia. of Base	250mm
Inner box	840×320×50×50mm(1pcs)
Master Carton	860×390×130mm(4pcs)
Weight	5kg(Inner box / 1pcs)



DD018B/W

Height	380mm
Arm Length	500mm
Rod Diameter	φ13-19mm
Inner box	120×70×530mm(1pcs)
Master Carton	380×260×560mm(10pcs)
Weight	1.2kg(Inner box/1pcs)



MICROPHONE STANDS AND ACCESSORIES



DE017

F: 5/8-27"
M: 3/8-16"
Master Carton:
520×220×140mm(100pcs)



DE018

F: 5/8-27"
M: 3/8-16"
Master Carton:
520×22×140mm(100pcs)



DE019

F: 3/8-16"
M: 5/8-27"
Master Carton:
520×220×140mm(100pcs)



DE020

F: 3/8-16"
M: 1/2"
Master Carton:
520×220×140mm(100pcs)



DE021

F: 1/2"
M: 3/8-16"
Master Carton:
520×220×140mm(100pcs)



DE022

M: 5/8-27"
I.D: φ 22-30
Master Carton:
460×400×280mm(250pcs)



DE023

M: 5/8-27"
I.D: φ 22-30
Master Carton:
460×400×280mm(250pcs)



DE024

ID: φ 33
Master Carton:
460×400×280mm(250pcs)



DE026

F: 5/8-27"
Master Carton:
400×400×320mm(100pcs)



DE027

M: 5/8-27"
I.D: φ 24-28
Master Carton:
460×400×280mm(250pcs)



DE028

M: 5/8-27"
I.D: φ 24-28
Master Carton:
460×400×280mm(250pcs)



DE029

M: 5/8-27"
I.D: φ 27-30
Master Carton:
460×400×280mm(250pcs)



DE030

M: 5/8-27"
I.D: φ 22-25
Master Carton:
460×400×280mm(250pcs)



DE031

M: 5/8-27"
I.D: φ 22-25
Master Carton:
460×400×280mm(250pcs)



DE032

M: 5/8-27"
I.D: φ 25-30
Master Carton:
460×400×280mm(250pcs)



DE048

M: 5/8-27"
I.D: φ 22-25
Master Carton:
460×400×280mm(250pcs)



DE049

M: 5/8-27"
I.D: φ 31
Master Carton:
460×400×280mm(250pcs)



DE060

M: 5/8-27"
I.D: φ 21
Master Carton:
320×220×220mm(250pcs)

MICROPHONE STANDS AND ACCESSORIES

GOOSENECK FOR MICROPHONE HOLDERS



DE051

Height: 125mm
Dia.of Base: 70mm
Master Carton:
400×400×230mm(50pcs)



DE033

Height: 105mm
Dia.of Base: 70mm
Master Carton:
400×400×230mm(50pcs)



DE034

Height: 115mm
Dia.of Base: 85mm
Master Carton:
480×200×260mm(20pcs)



DE053

Height: 20mm
Dia.of Base: 60mm
Master Carton:
570×220×140mm(200pcs)



DE058

Master Carton:
570×220×140mm(40pcs)



DE050



EE027



EE031



DE035

Master Carton:
420×220×300mm(50pcs)



DE036

Master Carton:
420×220×300mm(50pcs)



DE037

Master Carton:
420×250×350mm(100pcs)



DE052

Master Carton:
460×400×280mm(50pcs)



EE041



EE038



DE038B/W



3/8"-3/8"
O.D: 11X200mm(8")

DE039B/W



3/8"-3/8"
O.D: 15X200mm(8")

DE040B/W



3/8"-3/8"
O.D: 15X300mm(12")

DE041B/W



3/8"-3/8"
O.D: 15X400mm(16")

DE042B/W



3/8"-3/8"
O.D: 18.5X500mm(20")

DE043B/W



3/8"-3/8"
O.D: 18.5X600mm(24")

DE044B/W



3/8"-XLR(F)
O.D: 15X300mm(12")

DE045B/W



3/8"-XLR(F)
O.D: 15X400mm(16")

DE046B/W



XLR(M)-XLR(F)
O.D: 15X300mm(12")

DE047B/W



XLR(M)-XLR(F)
O.D: 15X400mm(16")

DE055B/W



5/8"-5/8"
O.D: 15X300mm(12")

DE056B/W



5/8"-5/8"
O.D: 15X400mm(16")

DB066B

Height	1180-1800 mm
Base Diameter	1100 mm
Load Capacity	50 kg
Material	Aluminum & Steel
Inner box	130x120x1060mm(1pcs)
Master Carton	280x380x1090mm(6pcs)
Weight	3kg(Inner box/1pcs)

CHINA PATENT # ZL200630156996.1



Crank-up speaker stand

DB019B

Height	1480-2420mm
Load Capacity	80kg
Material	Steel
Inner box	170x140x1530mm(1pcs)
Master Carton	300x190x1550mm(2pcs)
Weight	10kg(Inner box/1pcs)



Air-cushion speaker stand

DB035B

Height	1080-1800mm
Load Capacity	60kg
Material	Aluminum
Inner box	140x130x1100mm(1pcs)
Master Carton	300x280x1130mm(4pcs)
Weight	3.7kg(Inner box/1pcs)

This speaker stand utilizes compress air principle. It can protect the speaker from sudden drop when not secure properly.



DB020B

Height	1140-2000mm
Load Capacity	60kg
Material	Steel
Inner box	140x130x1100mm(1pcs)
Master Carton	300x280x1120mm(4pcs)
Weight	5.75kg(Inner box / 1pcs)



DB088B/S

Adjust Height	1100-2010mm
Load Capacity	60kg
Weight	3kg
Material	Aluminum & Steel
Inner box	130x130x1190mm(1pcs)
Master Carton	1210x280x415mm(6pcs)

DB089B/S

Adjust Height	1025-2440mm
Load Capacity	50kg
Weight	2.5kg
Material	Aluminum & Steel
Inner box	130x120x1060mm(1pcs)
Master Carton	380x280x1100mm(6pcs)



DB021B/W

Height	1000-2000mm
Load Capacity	60kg
Material	Aluminum
Inner box	140x130x1100mm(1pcs)
Master Carton	300x280x1120mm(6pcs)
Weight	3kg(Inner box / 1pcs)

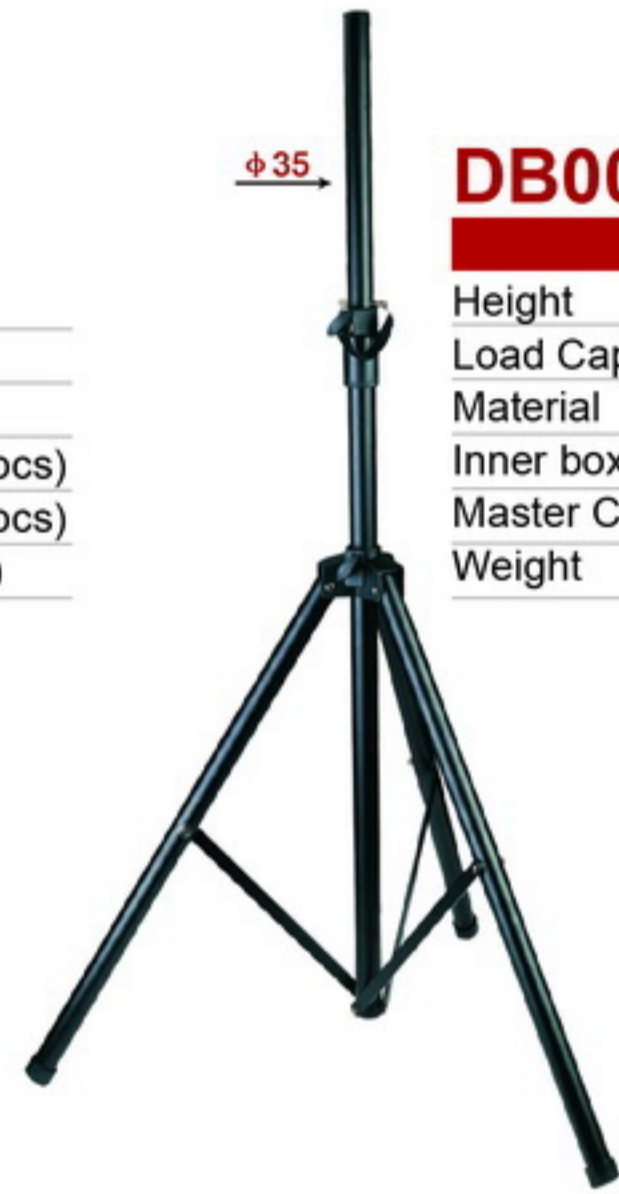

DB009B/W

Height	1000-1800mm
Load Capacity	50kg
Material	Aluminum
Inner box	130x120x1060mm(1pcs)
Master Carton	380x280x1090mm(6pcs)
Weight	2.5kg(Inner box/1pcs)

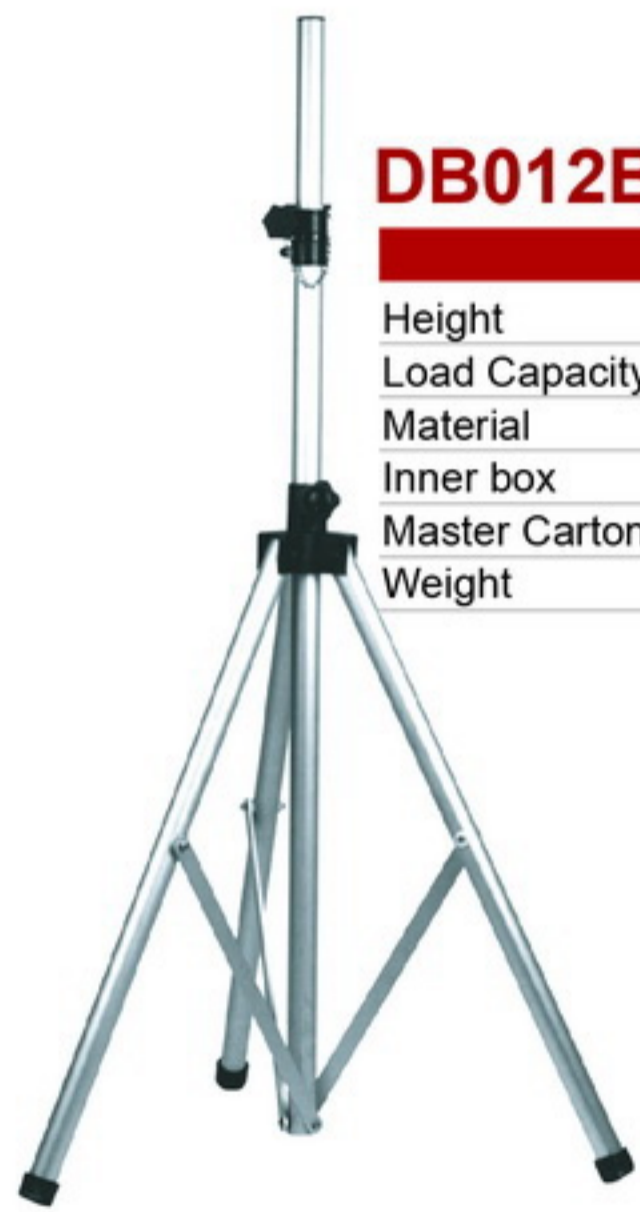

DB012B/W

Height	1000-1800mm
Load Capacity	50kg
Material	Aluminum
Inner box	130x120x1060mm(1pcs)
Master Carton	380x280x1090mm(6pcs)
Weight	2.5kg(Inner box/1pcs)



DB006B/W

Height	1250-2400mm
Load Capacity	60kg
Material	Aluminum
Inner box	140x130x1350mm(1pcs)
Master Carton	410x300x1380mm(6pcs)
Weight	3.5kg(Inner box/1pcs)



DB023B

Height	800-1340mm
Load Capacity	50kg
Material	Steel
Inner box	100x60x810mm(1pcs)
Master Carton	320x220x830mm(10pcs)
Weight	1.5kg(Inner box/1pcs)

DB039B

Height	690-1300mm
Plate size	230x230mm
Base(WxD)	450x450x450mm
Material	Steel
Inner box	850x500x60x70mm(1pcs)
Master Carton	600x160x880mm(4pcs)
Weight	5kg(Inner box / 1pcs)

DB081

Height	800-1100mm
Load Capacity	60kg
Material	Steel
Inner box	170x62x790mm(1pcs)
Master Carton	190x145x810mm(2pcs)
Weight	3kg(Inner box/1pcs)



DB078
Cabinet stand (wall installation)

Load Capacity	40kg
Material	steel
Inner box	155x110x620mm(1pcs)
Master Carton	350x330x650mm(6pcs)
Weight	3kg(Inner box/1pcs)



DB087
wall bracket for speaker

Load Capacity	30kg
Inner box	270x85x400mm
Master Carton	360x295x430mm(6pcs)
Weight	2kg

DB075
Speaker pole

Screw Thread:	M20
Max. Weight capacity:	80Kg
Shipping Package:	22x32x78cm(10pcs)

DC016
Speaker Mount

Screw Thread:	M20
Hole Pitch:	Φ82 mm
Shipping Package:	57x46x18cm(100pcs)

DC016

SPEAKER STANDS



DC001

I.D: 35mm
Material: Plastic
Master Carton:
460x400x280mm (50pcs)



DC002

I.D: 25mm
Material: Plastic
Master Carton:
460x400x280mm(100pcs)



DC004

I.D: 35mm
Height: 90mm
Material: Metal
Master Carton:
460x400x280mm(100pcs)



DC005

I.D: 25mm
Height: 85mm
Material: Metal
Master Carton:
420x220x300mm(100pcs)



DC006

I.D: 35mm
Height: 90mm
Material: Plastic
Master Carton:
460x400x280mm (100pcs)



DC007

I.D: 35mm
Height: 97mm
Material: Metal
Master Carton:
460x400x280mm(100pcs)



**DC008
DC009**

I.D: 35mm(DC008)
I.D: 38mm(DC009)
Material: Steel
Master Carton:
420x220x300mm(25pcs)
Weight: 0.19kg



DC010

I.D: 35mm
O.D: 38x100mm
Material: Plastic
Master Carton:
460x400x280mm(200pcs)
Weight: 0.14kg



DC011

I.D: 25mm
O.D: 35x80mm
Material: Plastic
Master Carton:
460x240x280mm(200pcs)
Weight: 0.11kg



DC012

I.D: 25mm
O.D: 35x80mm
Material: Metal
Master Carton:
420x220x300mm(50pcs)



DB010

Load Capacity: 18kg
Weight: 0.7kg
Material: Steel
Shipping Package:
120x105x105mm(1pcs)
Master Carton:
540x250x220mm(20pcs)
Weight: 1kg



DB011

Load Capacity: 18kg
Weight: 0.7kg
Material: Steel
Shipping Package:
120x105x105mm(1pcs)
Master Carton:
540x250x220mm(20pcs)
Weight: 1kg



DB038

Height: 150mm
Plate Size: 60x310mm
Material: Steel
Shipping Package:
320x160x70mm(1pcs)
Master Carton:
340x340x370mm(10pcs)
Weight: 1kg

"X" KEYBOARD STANDS



DF002

Height: 640-980 mm
Arm Length: $\Phi 30 \times 330$ mm
Material: Steel
Inner box: 120x70x990mm(1pcs)
Master Carton: 260x230x1010mm(6pcs)
Weight: 2.9kg(Inner box/ 1pcs)
load capacity: 40kg

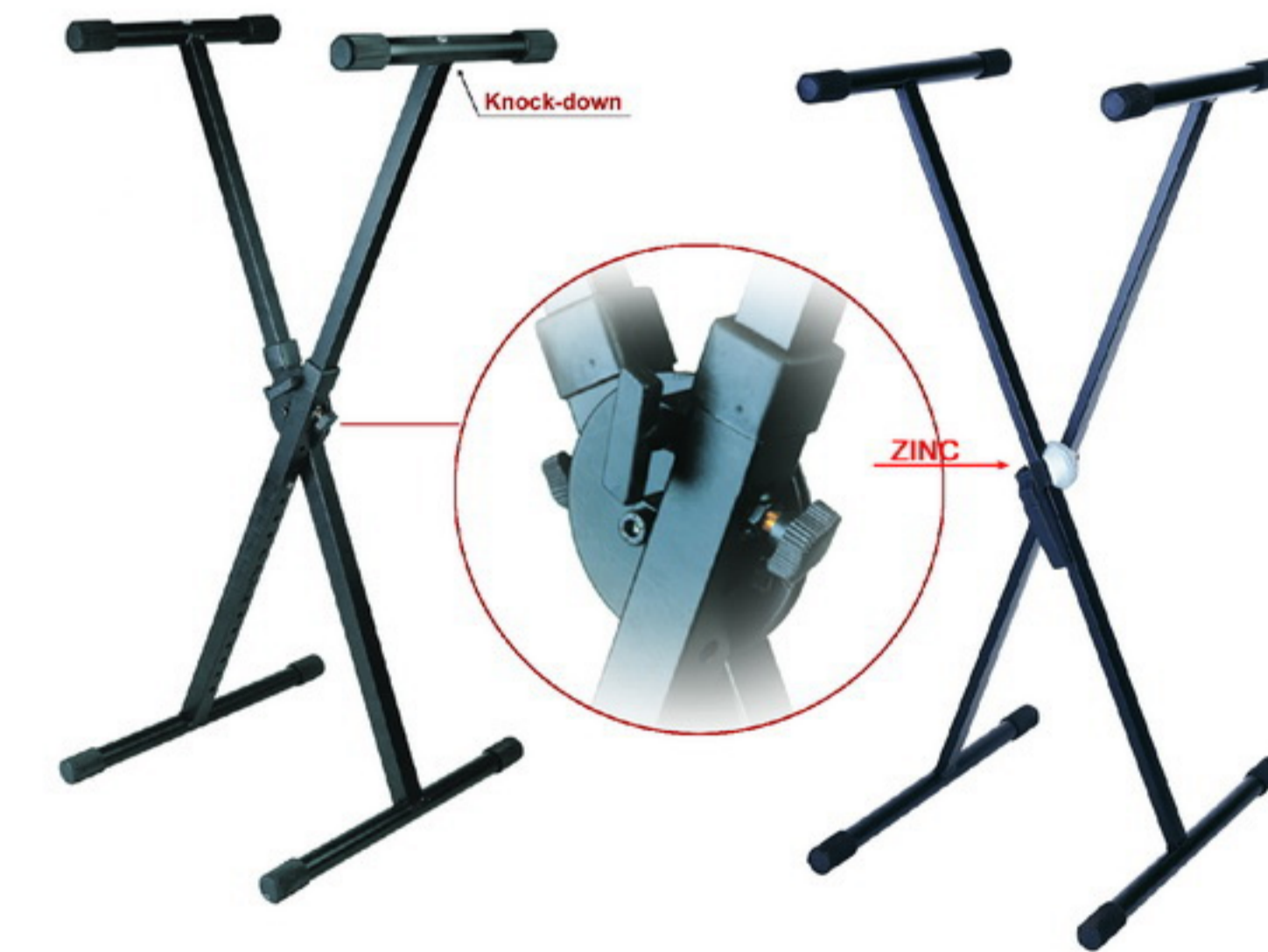

DF085

Height: 380-1130 mm
Arm Length: $\phi 30 \times 350$ mm
Material: Steel
Inner box: 15x9x71cm(1pc)
Master Carton: 32x20x73cm(4pcs)
Weight: 4.6kg(Inner box / 1pc)
load capacity: 40kg

DF029

Height: 170-970 mm
Arm Length: $\Phi 28 \times 400$ mm
Material: Steel
Inner box: 510x70x1020mm(1pcs)
Master Carton: 530x300x1050mm(4pcs)
Weight: 4.3kg(Inner box /1pcs)
load capacity: 40kg

"X" KEYBOARD STANDS

"X" KEYBOARD STANDS



DF032

Height	170-970 mm
Arm Length	Φ28×400 mm
Material	Steel
Inner box	510×70×1020mm(1pcs)
Master Carton	530×300×1050mm(4pcs)
Weight	4.3kg(Inner box / 1pcs)
load capacity	60kg



DF007

Height	450-990mm
Arm Length	φ30×350mm
Material	Steel
Inner box	510×100×1040mm(1pcs)
Master Carton	530×430×1080mm(4pcs)
Weight	5.7kg(Inner box / 1pcs)
load capacity	60kg



DF043

Height	560-920 mm
Arm Length	φ30×350 mm
Material	Steel
Inner box	480x80x1050mm(1pcs)
Master Carton	500x350x1070mm(4pcs)
Weight	4.6kg(Inner box / 1pcs)
load capacity	40kg



DF036

Height	470-1310 mm
Arm Length	φ30X350 mm
Material	Steel
Inner box	650x170x1030mm(1pcs)
Master Carton	670x350x1050mm(2pcs)
Weight	8.8kg(Inner box / 1pcs)
load capacity	60kg



DF008

Height	640-980 mm
Arm Length	φ30×330 mm
Material	Steel
Inner box	510×100×1040mm(1pcs)
Master Carton	530×430×1080mm(4pcs)
Weight	2.9kg(Inner box / 1pcs)
load capacity	40kg



DF068

Height	630-975mm
Arm Length	φ30×350mm
Material	Steel
Inner box	510×100×1040mm(1pcs)
Master Carton	530×430×1080mm(4pcs)
Weight	5.7kg(Inner box / 1pcs)
load capacity	60kg



DF111

X keyboard stand (disassembled)

Height	640-980 mm
Arm Length	φ25x335 mm
Material	Steel
Inner box	120x70x990
Master Carton	260x230x1010mm(6pcs)
load capacity	40kg



DF086

Height	470-1580 mm
Arm Length	φ30×350 mm
Material	Steel
Inner box	660x150x1050mm(1pcs)
Master Carton	680x320x1070mm(2pcs)
Weight	8kg(Inner box / 1pcs)
load capacity	60kg



SF609
Telescopic Music Stand

Specification:
Upper layer dimension: 800X1000mm
Upper layer height: 150mm
Lower layer dimension: 1000X1200mm
Lower layer height: 150mm
Package: 1100x1250x320mm

●Reliable podium, convenient for transportation.



SF400 **NEW**

Introduction:
19" peripheral equipment with 1U height can be installed on the upper part, the rotary knobs on two sides can adjust the operating angle of panel, the lower part of panel can hang several headphone devices; the rotary knob in the middle part of stand can adjust the telescopic height of telescopic tube, the lower part of stand has the stable pentagonal base, easy to carry and brake, convenient operation for user.

Specification:
Height Setting: 790-1060mm
Weight: 6.0kg/PCS
Diameter of Base: \varnothing 585mm
Material: steel+plastic
Color: black
Inner Box: 565x220x570mm(1pcs)
Master Carton: 695x585x605mm(3pcs)

DF151
Music Sheet Stand

Instruction:
A new style music stand with one-hand system, is easy to raise and lower the height of the stand, it is very applied.

Adjustable Height 1165-1565 mm
Plate Size 345x487 mm
Master Carton 400x380x890mm(4in)

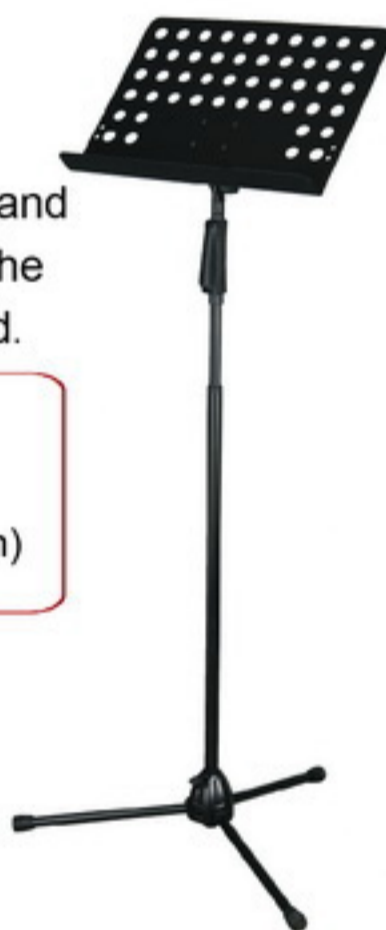

DF152-1
Music Sheet Stand

Adjustable Height 880-1250mm
Plate Size 345x475mm
Weight 3kg
Inner box 385x95x802mm
Master Carton 820x790x220mm



DF144

Height 940-1420
Panel size 475-345
Material Steel Plastic
Inner box 360x120x640mm(1pcs)
Master Carton 630x370x670mm(4pcs)
Weight 3.8kg(Inner box / 1pcs)



DF014

Height 940-1420 mm
Book Plate Size 475(W)x345(D)mm
Material Steel
Inner box 360x120x640mm(1pcs)
Master Carton 630x370x670mm(5pcs)
Weight 3.8kg(Inner box / 1pcs)

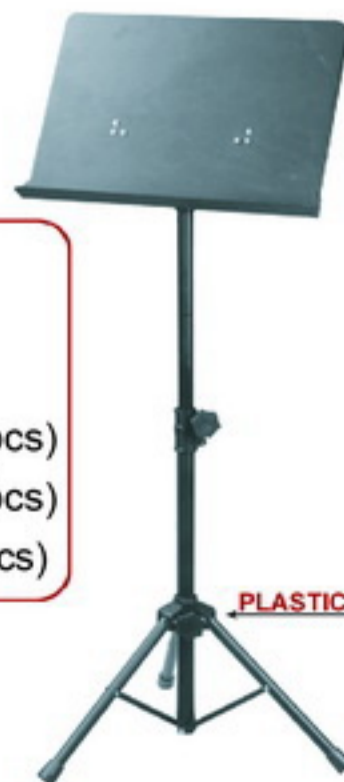

Introduction:
●Fantastic lamp
●Easy to carry

SML100



Application:



SML200



SML300



Application:





DF013

Height	940-1420 mm
Book Plate Size	475(W)x345(D)mm
Material	Steel
Inner box	360x120x640mm(1pcs)
Master Carton	630x370x670mm(5pcs)
Weight	3.8kg(Inner box / 1pcs)



DF013-2

Height	940-1420 mm
Book Plate Size	475x345 mm
Material	Steel
Inner box	360x120x640mm(1pcs)
Master Carton	630x370x670mm(5pcs)
Weight	3.8kg(Inner box / 1pcs)



DF091

Height	940-1420 mm
Book Plate Size	475(W)x345(D) mm
Material	Steel
Inner box	360x120x640mm(1pcs)
Master Carton	630x370x670mm(5pcs)
Weight	4.3kg(Inner box / 1pcs)



DF048

Height	900-1300 mm
Book Plate Size	500-975(W)X340(D)mm
Material	Steel
Inner box	360x120x640mm(1pcs)
Master Carton	630x370x670mm(5pcs)
Weight	6kg(Inner box/1pcs)



DF050

Height	940-1420 mm
Book Plate Size	475(W)x345(D) mm
Material	Steel
Inner box	360x120x640mm(1pcs)
Master Carton	630x370x670mm(5pcs)
Weight	4kg(Inner box / 1pcs)



DF052

Height	1100-1500mm
Book Plate Size	475(W)X345(D)mm
Material	Steel
Inner box	500x140x500mm(1pcs)
Master Carton	730x520x520mm(5pcs)
Weight	4kg(Inner box / 1pcs)



DF009

Height	640-1270 mm
Book Plate Size	505(W)x290(D) mm
Material	Steel
Inner box	70x70x540mm(1pcs)
Master Carton	380x300x560mm(20pcs)
Weight	1.25kg(Inner box/1pcs)



DF049

Height	740-1380 mm
Book Plate Size	465(W)x230(D)mm
Material	Steel
Inner box	90x90x540mm(1pcs)
Master Carton	470x380x560mm(20pcs)
Weight	1.9kg(Inner box / 1pcs)



DF051

Height	850-1480 mm
Book Plate Size	465(W)×230(D) mm
Material	Steel
Inner box	90×60×540mm(1pcs)
Master Carton	380×320×560mm(20pcs)
Weight	1.5kg(Inner box / 1pcs)



DF088

Height	1050-1600 mm
Book Plate Size	507(W)×325(D) mm
Material	Steel
Inner box	580×480×120mm(1pcs)
Master Carton	490×470×610mm(4pcs)
Weight	4kg(Inner box / 1pcs)



DF015

Height	940-1450 mm
Book Plate Size	480(W)×350(D)mm
Material	Steel
Inner box	360×120×640mm(1pcs)
Master Carton	630×370×670mm(5pcs)
Weight	3.8kg(Inner box / 1pcs)



SIP105-1

Multi-purpose IPAD stand

Used to fix iPad or Android Pad with 7-14 inches screen
 Inner box : 275×120×100 mm
 master box : 570×380×230 mm(12pcs)
 weight : 0.64kg



SIP105
Multi-purpose IPAD stand
 Used to fix iPad or Android Pad with 7-10 inches screen
 Inner box : 240×115×100 mm
 master box : 500×370×230 mm(12pcs)

CBM :
 Inner box : 240×115×100 mm
 master box : 500×370×230 mm
 Weight : 0.5kg



DF136
Computer Holder

Height	920-1300 mm
Plate size	350×320cm
Material	Steel
Inner box	320×150×760mm(1pcs)
Master Carton	660×320×790mm(4pcs)
Weight	5kg(Inner box/1pcs)



SD001

Diameter	300mm
Min height adjustment	490mm
Max height adjustment	590mm



SD002

saddle contour	
Min height adjustment	480mm
Max height adjustment	570mm



DF059

Height	520 mm
Plate Size	φ330 mm
Material	Steel
Inner box	350x170x470mm(1pcs)
Master Carton	880x370x490mm(5pcs)
Weight	3.8kg(Inner box / 1pcs)



DF019

Height	430-480 mm
Arm Length	405(W)x305(D)mm
Material	Steel
Inner box	320x120x580mm(1pcs)
Master Carton	630x340x610mm(5pcs)
Weight	4.3kg(Inner box / 1pcs)

KEYBOARD BENCH



DF089

Height	600-810 mm
Arm Length	φ330 mm
Material	Steel
Inner box	350x170x470mm(1pcs)
Master Carton	880x370x490mm(5pcs)
Weight	4kg(Inner box / 1pcs)



Folding Keyboard bench

DF074

Height	550-620 mm
Arm Length	600(W)x300(D)mm
Material	Steel
Inner box	340x150x770mm(1pcs)
Master Carton	620x360x790mm(4pcs)
Weight	6kg(Inner box / 1pcs)



DF084

Height	590-900mm
Base Size	600~1000(W)x615(D)mm
Material	Steel
Inner box	600x90x620mm(1pcs)
Master Carton	630x380x640mm(4pcs)
Weight	8.12kg(Inner box / 1pcs)



DF018

Height	650-1100mm
Base Size	735~1300(W)x240(D)mm
Material	Steel
Inner box	390x130x740mm(1pcs)
Master Carton	410x630x770mm(5pcs)
Weight	7.5kg(Inner box / 1pcs)



DF075

Height	490-580 mm
Arm Length	530(W)x240(D) mm
Material	Steel
Inner box	350x140x650mm(1pcs)
Master Carton	720x370x680mm(5pcs)
Weight	5.2kg(Inner box / 1pcs)



DF022

Height	695 mm
Base Size	645(W)x550(D)mm
Material	Steel
Inner box	620x80x710mm(1pcs)
Master Carton	640x340x730mm(4pcs)
Weight	7.2kg(Inner box / 1pcs)

RACK STANDS



DF025

Height	915 mm
Base Size	560(W)x560(D)mm
Material	Steel
Inner box	880x580x140mm(1pcs)
Master Carton	900x300x600mm(2pcs)
Weight	14kg(Inner box / 1pcs)

MULTI-FUNCTION STANDS CARRIER

DF129KD

Height:	43 - 109.2 cm
Width:	22 - 55.9 cm
Length:	5 - 151.5 cm
Weight:	14 kg
Color:	Black

Storage cart for sheet music stands:

- Holds up to 10 orchestra sheet music stands model DF013
- Allows fast removal and easy racking of music stands, as well as neat storage in a very small space
- Designed for indoor use, easy to maneuver on all floor surfaces
- Sturdy steel construction for safe support and years of reliability, this practical cart features durable powder coated finish and roller bearing wheels



DG036-3

Inner box	480x130x820mm
master carton	680x500x850mm(5pcs)
Weight	3.6kg



DG036-4

Height	755mm
Inner box	820x140x600mm
master carton	840x300x620mm(1:2)
Weight	4kg

GUITAR STANDS



DG031

Height	685-910 mm
Material	Steel
Master Carton	270x180x670mm(6pcs)
Weight	1.3kg(Inner box / 1pcs)



DG036-5

Inner box	680x130x820mm
master carton	700x680x850mm(5pcs)
Weight	4.6kg



DG036-7

Inner box	880x815x150mm
master carton	900x835x330mm(1:2)
Weight	6kg



DG062

Guitar stand (Electric/Wood dual application)

Height	480-750 mm
Applications	One or Two Guitar Holder
Material	Steel
Inner box	100x490x530mm(1pcs)
Master Carton	720x540x570mm(6pcs)



DG061

Guitar stand (Electric/Wood dual application)Adjustable height

Height	310-720mm
Applications	Single Guitar Stand
Material	Steel
Inner box	120x95x565mm(1pcs)
Master Carton	380x210x590mm(6pcs)
Weight	2.28kg



DG024

Wood guitar stand

Height	440 mm
A-Frame Size	210-345 mm
Material	Steel
Inner box	320x110x460mm(1pcs)
Master Carton	580x340x480mm(6pcs)
Weight	1.85kg(Inner box / 1pcs)



DG015

Height	640-770 mm
Material	Steel
Master Carton	270x160x630mm(6pcs)

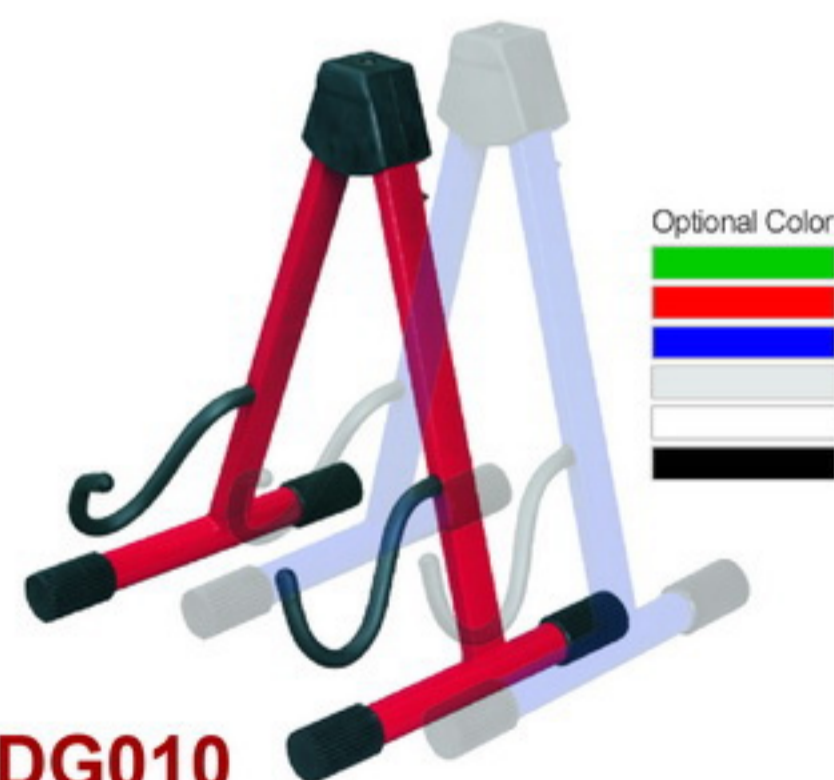

DG010

Electric guitar stand

Height	440 mm
A-Frame Size	210-345 mm
Material	Steel
Inner box	320x80x460mm(1pcs)
Master Carton	520x340x480mm(6pcs)
Weight	1.85kg(Inner box / 1pcs)



DG012

Wood guitar stand

Height	440 mm
A-Frame Size	210-345 mm
Material	Steel
Inner box	320x80x460mm(1pcs)
Master Carton	520x340x480mm(6pcs)
Weight	1.85kg(Inner box / 1pcs)



DG016

Height	660-780 mm
Material	Steel
Master Carton	270x160x630mm(6pcs)



DG030

Height	635-750 mm
Material	Steel
Inner box	180x120x520mm(1pcs)
Master Carton	270x160x630mm(6pcs)
Weight	1.2kg(Inner box / 1pcs)

DG096A

Material	Steel +EVA+TPE
Inner box	105x80x372mm
Master Carton	260x230x400mm (1:6)
Weight	0.5 kg



DG096A Application

PATENT:201130115164.6

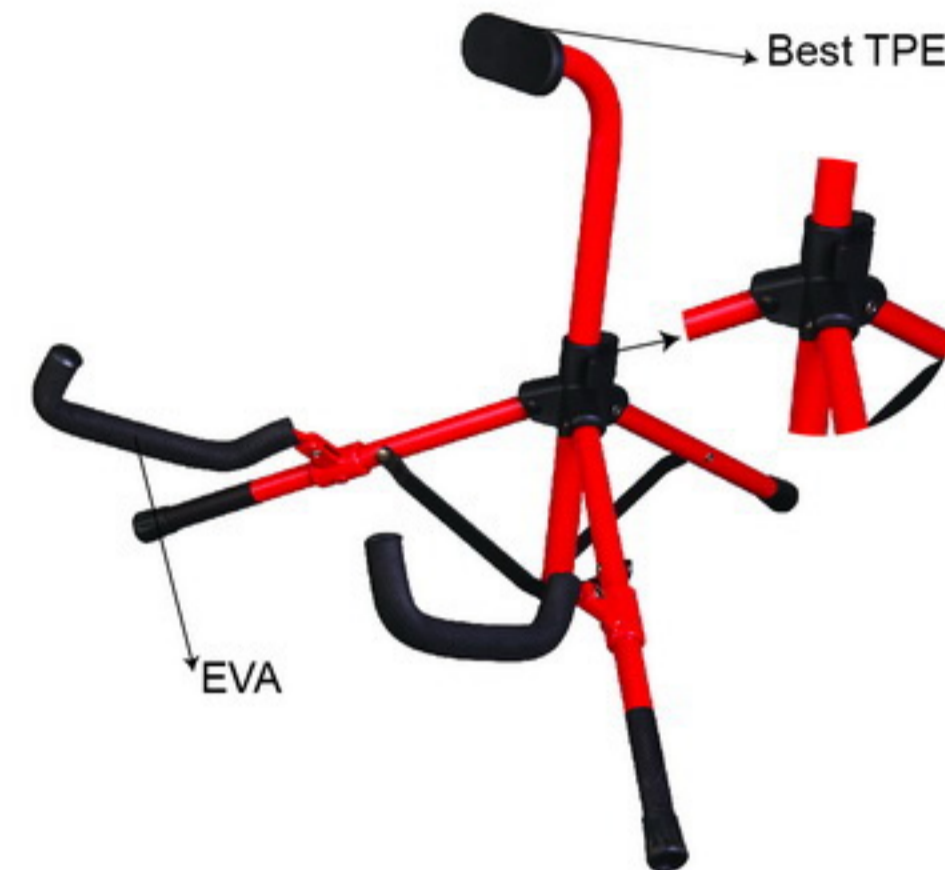

DG096B

Material	Steel +EVA+TPE
Inner box	105x80x372mm
Master Carton	260x230x400mm (1:6)
Weight	0.55 kg



DG096B Application

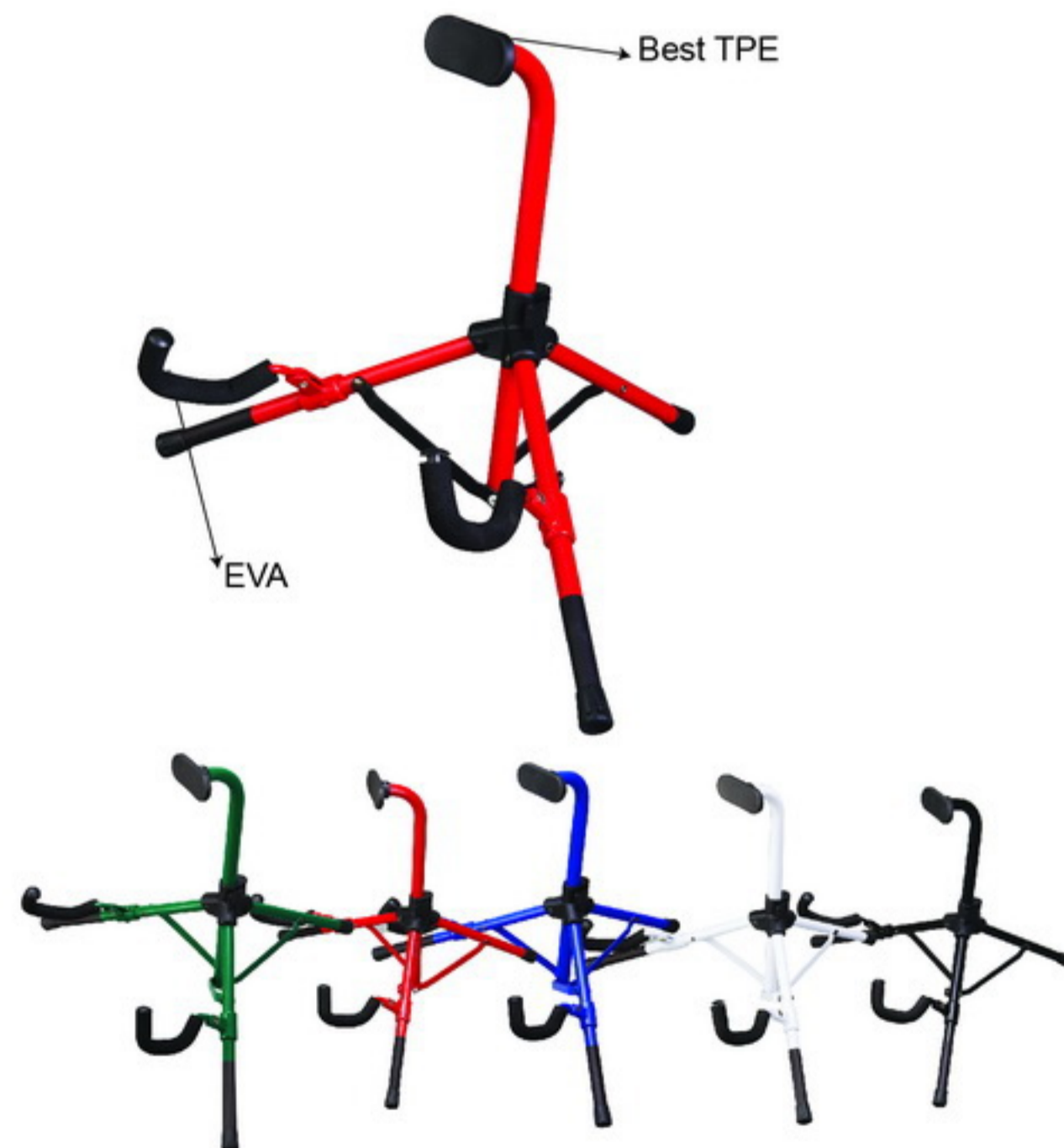

Optional Colors



DG063

Specification:

Adjustable Height: 800-1100 mm
 Material: Steel and Plastic
 Weight Capacity: 15 kg
 Inner box: 160x120x805mm (1 pcs)
 Master Carton: 380x340x825mm (6 pcs)

CHINA PATENT NO.: 200720184551.3



DG077

Specification

Adjustable Height: 700-1180 mm
 Weight Capacity: 15 kg
 Material: Steel, Plastic
 Inner box: 155x105x710mm (1pcs)
 Master Carton: 330x325x730mm (6pcs)
 CHINA PATENT NO.: 200720184551.3



Open



Self-securing

Optional Colors



GUITAR STANDS



DG088 Self-lock Guitar Stand

This stand adopts V yoke to suit for various guitars. The back-folded yoke structure reduces the packing size greatly.

Adjustable Height: 800-1100
Load: 15kg
Material: Steel Plastic
Inner box: 140×110×855mm(1pcs)
Master Carton: 350×300×885mm(6pcs)
Weight: 2kg(Inner box/1pcs)



DG089 Self-lock Guitar Stand

This stand adopts V yoke to suit for various guitars. The back-folded yoke structure reduces the packing size greatly.

Adjustable Height: 685-1100
Load: 15kg
Material: Steel Plastic
Inner box: 90×100×725mm(1pcs)
Master Carton: 290×220×755mm(6pcs)
Weight: 2kg(Inner box/1pcs)



GUITAR FOOT STOOLS & ACCESSORIES

Optional Colors:



DG001(FOOT STOOL)

Inner box:115×20×300mm(1pcs)
Master Carton:260×240×320mm(20pcs)
Weight:0.8kg(Inner box/1pcs)



DG004

Master Carton:
400×400×280mm(50pcs)



DG006

Master Carton:
400×400×280mm(50pcs)



DG040

Master Carton:
480×380×180mm(40pcs)

AUDIOVISUAL STANDS

GUITAR AMPLIFIER STANDS



DG019

Height: 320 mm
Base Size:305(W)×405(D) mm
Material: Steel
Inner box:370×35×650mm(1pcs)
Master Carton:390×380×670mm(10pcs)
Weight: 1.25kg(Inner box/1pcs)



DG020

Height: 610-740 mm
Base Size:420(W)×500(D) mm
Material: Steel
Inner box:510×70×520mm(1pcs)
Master Carton:530×370×550mm(5pcs)
Weight: 4.25kg(Inner box/1pcs)

DG021

Height: 430-980 mm
Base Size:400(W)×330-580(D) mm
Material: Steel
Inner box:410×90×1100mm(1pcs)
Master Carton:480×430×1130mm(5pcs)
Weight:3.2kg(Inner box / 1pcs)



DG022

Height:500-840 mm
Base Size:400(W)×330-580(D) mm
Material: Steel
Inner box:410×90×1000mm(1pcs)
Master Carton:480×430×1030mm(5pcs)
Weight:2.8kg(Inner box / 1pcs)



DG023

Height: 720-870 mm
Base Size:405(W)×280-520(D)mm
Material: Steel
Inner box:730×420×280×50mm(1pcs)
Master Carton:440×350×750mm(2pcs)
Weight:5kg(Inner box / 1pcs)



SAXOPHONE STANDS

BAGS FOR STANDS



DH010

Height: 190 mm
 Base: 130 mm
 Inner box:150x140x70mm(1pcs)
 Master Carton:320x300x350mm(20pcs)
 Weight:1.15kg(Inner box / 1pcs)



DH001

Height: 200-400 mm
 Material: Steel
 Inner box:90x90x500mm(1pcs)
 Master Carton:470x200x530mm(10pcs)
 Weight:0.7kg(Inner box / 1pcs)



DH002

Height: 740-1100 mm
 Material: Steel
 Inner box:90x90x630mm(1pcs)
 Master Carton:470x200x650mm(10pcs)
 Weight:1.3kg(Inner box / 1pcs)



DH003

Height: 790-860 mm
 Material: Steel
 Inner box:170x150x510mm(1pcs)
 Master Carton:770x360x540mm(10pcs)
 Weight:1.15kg(Inner box / 1pcs)



DH004

Height: 850-1210 mm
 Material: Steel
 Inner box:170x150x510mm(1pcs)
 Master Carton:770x360x540mm(10pcs)
 Weight:0.7kg(Inner box / 1pcs)



DH005

Height: 487-532 mm
 Material: Steel
 Inner box:130x120x390mm(1pcs)
 Master Carton:620x280x420mm(10pcs)
 Weight:1.3kg(Inner box / 1pcs)



DH006

Height: 505-530 mm
 Material: Steel
 Inner box:130x120x390mm(1pcs)
 Master Carton:620x280x420mm(10pcs)
 Weight:1kg(Inner box / 1pcs)



DH007

Height: 570-633 mm
 Material: Steel
 Shipping Package:130x120x390mm(1pcs)
 Master Carton:620x280x420mm(10pcs)
 Net. Weight:1.1kg(Inner box / 1pcs)



DH008

Height: 395-420 mm
 Material: Steel
 Inner box:380x280x95mm(1pcs)
 Master Carton:580x400x500mm(10pcs)
 Weight:2kg(Inner box / 1pcs)



Music Bag

DI001



Loud Speaker Stand

DI005



Music Stand

DI002



Speaker Stand&Cable Kit
(2PCS)

DI009



Microphone Stand

DI003



Lighting Stand

DI006



"X"Keyboard Stands

DI004



Microphone Stand&Cable Kit

(2PCS)

DI013



Lighting Stand
bag for DA010(1PC)

DI007



DLB003

Recommended Load Capacity	150kg / 330lbs
Maximum Height	4.80m / 15'7"
Minimum Height	1.95m / 6'4"
Base	2.13m / 7'
Folded Position	1.95m / 6'4"
Weight	63kg / 139lbs



Package (DLB005/DLB004/DLB006/DLB007)

DLB004

Recommended Load Capacity	180kg / 405lbs
Maximum Height	5.50m / 18'
Minimum Height	1.77m / 5'11"
Base	2.17m / 7'2"
Folded Position	1.77m / 5'11"
Weight	104kg / 229lbs

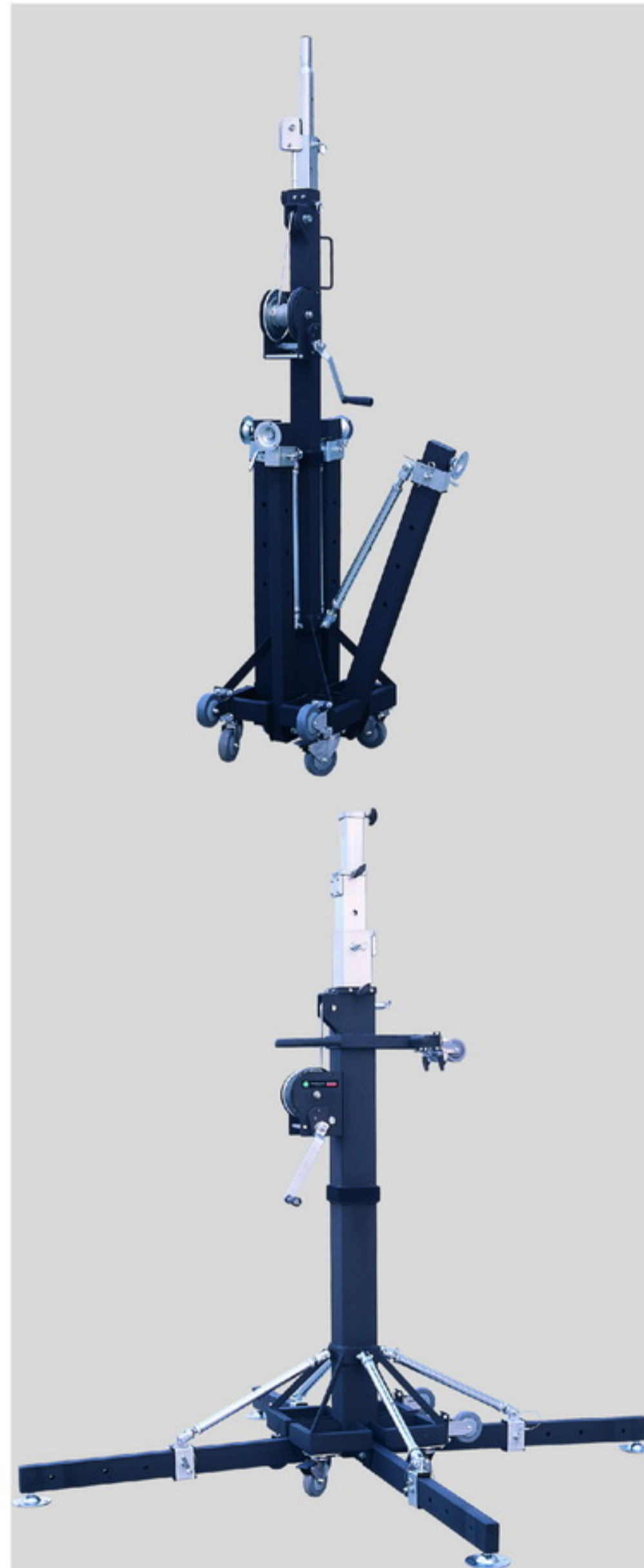

DLB005 (Aluminum)

Recommended Load Capacity	98kg / 215lbs
Maximum Height	6.00m / 19'8"
Minimum Height	1.80m / 5'11"
Base	2.70m / 7'12"
Folded Position	1.50m / 4'9"
Weight	55kg / 121 lbs

DRF010



Application



Applied to the DLB005 & DLB006 Speaker stand.
 Φ28 male connector.
 T bars for option:DRF007/DRF008

DLC005

Recommended Load Capacity	75kg / 165 lbs
Maximum Height	3.90m / 12'8"
Minimum Height	1.50m / 4'9"
Base	1.30m / 4'3"
Folded Position	1.50m / 4'9"
Weight	22kg / 48 lbs

DRF001



Application



Bar(like T)30×30mm-length1.5m (4.90inch)suitable for fastening 6-12 pieces of PAR light fastened on Φ35mm master tube of stand DLC005
 T bars for option:DRF001~DRF006





DLC001

Recommended Load Capacity	85kg / 187lbs
Maximum Height	4.00m / 13'2"
Minimum Height	1.75m / 5'9"
Base	1.60m / 5'3"
Folded Position	1.75m / 5'9"
Weight	25kg / 55lbs

T bars for option:DRF001~DRF006



Package (DLC001/DLC002)

DLC002

Recommended Load Capacity	65kg / 143lbs
Maximum Height	3.00m / 9'8"
Minimum Height	1.65m / 5'4"
Base	1.10m / 3'7"
Folded Position	1.65m / 5'4"
Weight	11kg / 24lbs

T bars for option:DRF001~DRF006



DRF001

T-bar 30x30mm-Length 1.5m(4.90")
Suitable for mounting 6 to 12 PAR cans.Can be mounted onto the top of a 35mm mast.

DRF002

Heavy duty T-bar 45x45mm-Length 1.5m(4.90") Suitable for mounting 6 to 12 PAR cans. Can be mounted onto the top of a 35mm mast.

DRF003

Reinforced T-bar 50mm-Length 1.5m(4.90") .
Must be used with CR50 hook clamp. Can be mounted onto the top of a 35mm mast.



DRF004

For securing (DLD△150 or DLD△200) on to the top of 35mm mast



DRF005

For securing (DKB△220/290 or DKB△390) on to the top of 35mm mast



DRF006

For stand DLB004 only. To fix trussing (△250-△250-△290-△350-△450-△290-△500)



DRC001

SpigotΦ28mm & Thread M10



DRC002

SpigotΦ28mm & Thread M10



DRB001

Fixing adapter for spigotΦ28. Suitable for the top of aΦ35mm mast



DRB002

ID.:35x120mm, Thread M10



DRB003

To mount a tubeΦ50mm on the top of aΦ35mm mast





DRB004

ID.:35x120mm, Thread M10



DPC001

Components For The Bridge

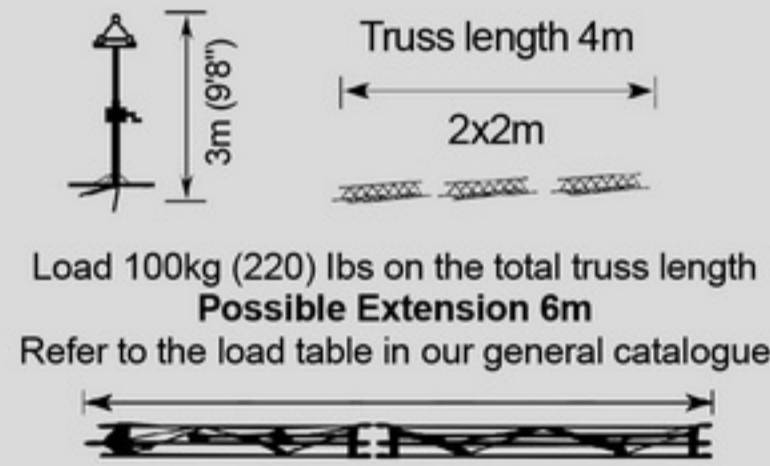

- 2 x  Model No. DLC002
- 2 x  Model No. DRF004
- 3 x  Model No. DLD150
Steel 150mm
Length 2m

Parts As Followings



DPC003



Components For The Bridge

- 2 x  Model No. DLC001
- 2 x  Model No. DRF005
- 3 x  Model No. DKB2903-200
Aluminium 290mm
Length 2m

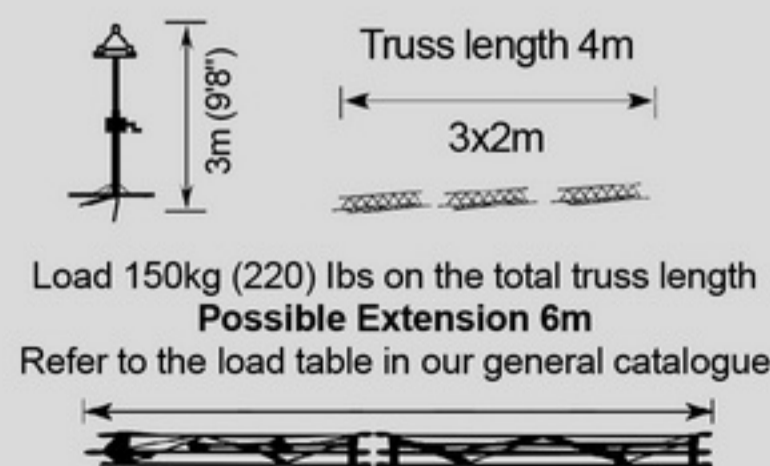
Parts As Followings



DA010

- 2 x  Model No. DA008
- 1 x  Model No. DA010-1

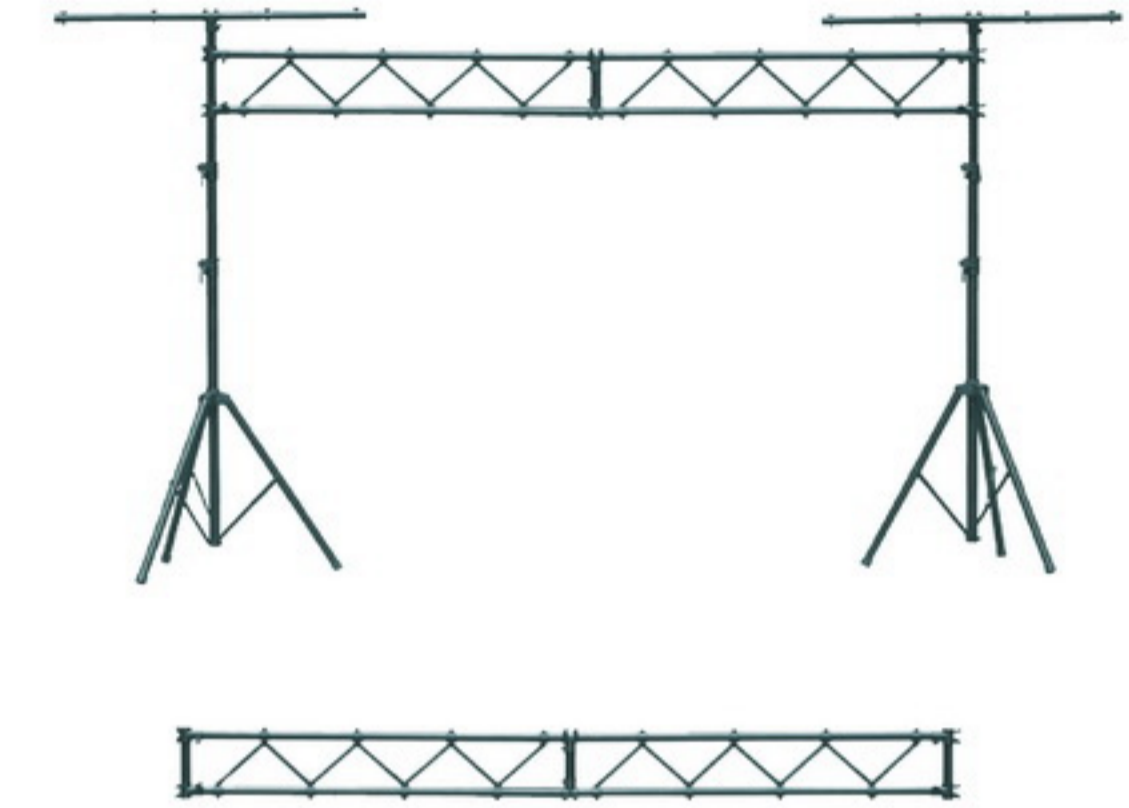

- Load Capacity: 100kg
- Height: 1620-3250mm
- Arm Length: 1500-3000mm
- T Bar Size: $\Phi 38 \times 1220$ mm
- Material: Aluminum
- Shipping Package: 370x230x1520mm(1set)
- Weight: 15kg(1set)

- Weight: 6kg(DA010-1)
- Weight: 9kg(DA008)
- Shipping Package: 350x90x1500mm(DA010-1)
- Shipping Package: 370x230x1520mm(DA008)



DA010-I

DA011

- 2 x  Model No. DA020
- 1 x  Model No. DA011-1

- Load Capacity: 120kg
- Height: 1620-3250mm
- Arm Length: 1500-3000mm
- T Bar Size: $\Phi 38 \times 1220$ mm
- Material: Steel
- Shipping Package: 37x25x152cm(1set)
- Weight: 36kg(1set)

- Net.Weight: 10kg(DA010-1)
- Net.Weight: 19kg(DA008)
- Shipping Package: 350x90x1500mm(DA010-1)
- Shipping Package: 370x250x1520mm(DA008)(1pcs)

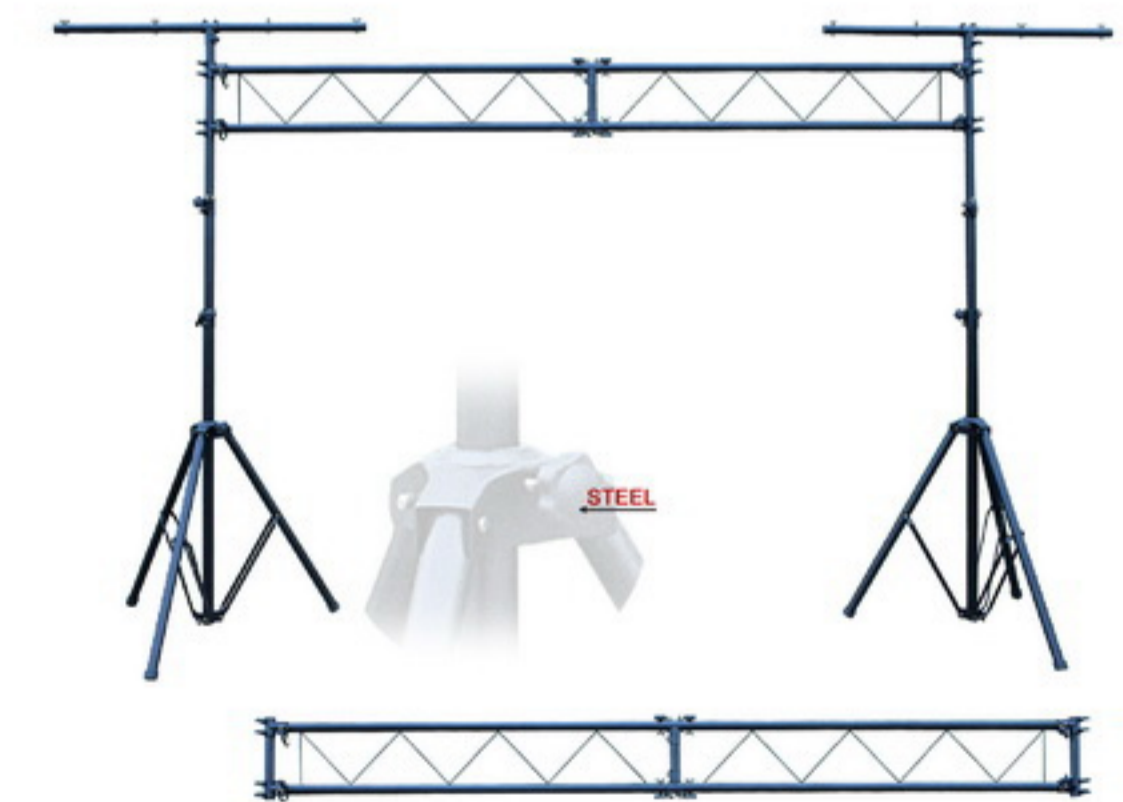

DA011-I



DA025

Height	2200-4000mm
Arm Length	35x35x1300mm
Load Capacity	85kg
Material	Steel
Master Carton	1830x350x250mm(1pcs)
Weight	27kg(Inner box/1pcs)



DA026

Height	1650-2700mm
Arm Length	35x35x1300mm
Load Capacity	65kg
Material	Steel
Master Carton	1910x217x200mm(1pcs)
Weight	13kg(Inner box/1pcs)



DA008

Height	1450-3250mm
Arm Length	Φ38x1220mm
Load Capacity	50kg
Material	Aluminum
Inner box	170x140x1360mm(1pcs)
Master Carton	360x300x1380mm(4pcs)
Weight	5kg(Inner box/1pcs)



DA009

Height	1450-3250mm
Arm Length	Φ38x1220mm
Load Capacity	60kg
Material	Aluminum
Inner box	190x150x1360mm(1pcs)
Master Carton	400x320x1380mm(4pcs)
Weight	6kg(Inner box/1pcs)



DA006

Height	1100-2500mm
Arm Length	25x25x950mm
Load Capacity	30kg
Material	Steel
Inner box	120x110x1110mm(1pcs)
Master Carton	260x240x1140mm(4pcs)
Weight	5kg(Inner box/1pcs)



DA020

Height	1450-3250mm
Arm Length	Φ38x1220mm
Load Capacity	60kg
Material	Steel
Inner box	200x160x1390mm(1pcs)
Master Carton	340x220x1430mm(2pcs)
Weight	8.5kg(Inner box/1pcs)