

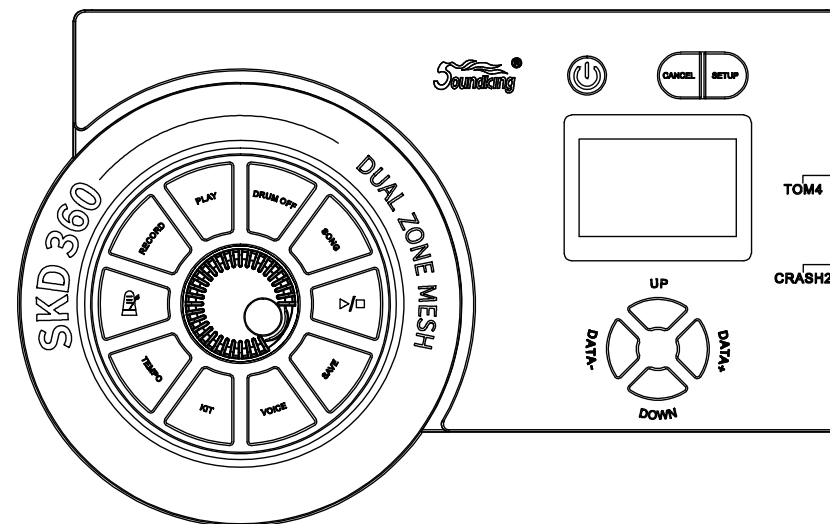

## OWNER'S GUIDE

Module:SKD360



**SOUNDKING AUDIO**

[WWW.SOUNDKING.COM](http://WWW.SOUNDKING.COM)

All rights reserved to SOUNDKING. No part of this manual may be reproduced, translated or photocopied by any means for any purpose, without the written permission of SOUNDKING.

The information involved in this manual is subject to change without notice.

**ECNJG2106168**

## Congratulations!

Thank you for purchasing this digital drum set. The drum set has been Developed to act and play like a drum set but with greater ease. Before you use the instrument, we recommend you to read through this manual.

### Taking care of Your Digital Drum Set

#### Location

- Do not expose the unit to the following Conditions to avoid deformation, discoloration or more serious damage.
- Direct sunlight.
- High temperature (near a heat)source, Or in car during the day time).
- Disconnect **all** cables before moving

#### Power Supply

- make sure to use the suitable AC adaptor, and also make sure the ac outlet voltage at your country matches the input voltage specified on the AC AC adaptor's label.
- Turn the power switch OFF When the Instrument is not in use.
- An AC adaptor should be unplugged from the AC outlet if the instrument is not be used for an extended period of time.
- Unplug the AC adaptor during electric storms.
- Avoid plugging the AC adaptor into -The same AC outlet as appliance with high power consumption, such as electric heaters or ovens. Also avoid using multi-plug adaptors since these can result in reducing the sound quality, operation errors, and possibly damage.

#### Turn Power OFF When Making Connections

- To avoid damage to the instrument and other devices to which it is Connected, turn the power switches of all related device OFF prior to connecting or disconnecting cables.

#### Handling and Transport

- Never apply excessive force to the controls, connectors or other parts of the instrument.
- Always unplug cables by gripping the plug firmly, but not pulling on the cable.
- Disconnect all cables before moving The instrument.
- Physical shocks caused by dropping, bumping, or placing heavy objects on the instrument can result in scratches more serious damage.

#### Cleaning

- Clean the unit with a dry soft cloth.
- A Slightly damp cloth may be used to Remove stubborn grime and dirt.
- Never use cleaners such as alcohol or thinner.
- Avoid placing vinyl object on top of The unit (uinyl can stick to and discolor the surface).

#### Electrical Interference

- This instrument contains digital circuitry and may cause interference if placed too close to radio or television receivers. If this occurs, move the instrument further away from the affected equipment.

**ECNJG2106168**

## DEMO SONG LIST

Number	Name	Meter	Tempo
DEMO 01	POP ROCK	4/4	90
DEMO 02	FUNK	4/4	110
DEMO 03	SHUFFLE	4/4	117
DEMO 04	SHUFFLE	4/4	128
DEMO 05	ROCKBLUES	4/4	105
DEMO 06	ROCK	2/4	120
DEMO 07	ROCK	4/4	138
DEMO 08	DANCE	2/4	140
DEMO 09	POP	4/4	123
DEMO 10	POP	4/4	100
DEMO 11	POP	4/4	82
DEMO 12	POP	4/4	159
DEMO 13	COUNTRY	4/4	120
DEMO 14	COUNTRY	4/4	108
DEMO 15	SWING	4/4	140
DEMO 16	WALTZ	3/4	180
DEMO 17	BOSSA	4/4	120
DEMO 18	RAGGE	4/4	110
DEMO 19	LATIN	4/4	180
DEMO 20	FLAMINGO	3/4	110

## CONTENT:

<b>ASSEMBLY GUIDE</b> .....	1	<b>EFFECT SETTING</b> .....	21
<b>CONNECTION</b> .....	2	EQ setting .....	21
<b>FUNCTION BUTTON DESCRIPTION</b> .....	3	Reverb setting .....	22
Front panel .....	3	<b>RELOAD DEFAULT SETTING</b> .....	22
Rear panel .....	3	Single user drum kit is restored to factory settings .....	22
Side panel .....	4	Drum pad triggering parameters restore factory settings .....	23
<b>CONNECT WITH EXTERNAL DEVICES</b> .....	6	All parameters restore factory settings .....	24
Connect to audio system or amplifier .....	6	<b>SELECT TRIGGER</b> .....	25
Connect to headphones .....	6	Tom and snare rim trigger setting .....	25
Connect to MP3 or CD player .....	7	HI-HAT trigger setting .....	25
Connect with computer .....	7	Kick sensor type .....	26
Connect to computer via MIDI .....	8	<b>MIDI SETTING</b> .....	27
Connect the MIDI keyboard via the MIDI port .....	8	MIDI connection .....	28
Connect with power supply .....	9	Connect with external audio device .....	28
<b>BASIC OPERATION</b> .....	9	Used as an audio source device .....	29
Selecting a drum kit .....	9	MIDI list .....	30
Playing the pads .....	10	<b>SYSTEM SOFTWARE UPDATE</b> .....	31
HI-HAT demonstration .....	11	<b>TROUBLE SHOOTING</b> .....	32
<b>DEMO SONG</b> .....	11	<b>AUDIO SOURCE SPECIFICATIONS</b> .....	33
Play and switch the DEMO SONG .....	11	<b>DRUM KIT LIST</b> .....	34
Adjusting DEMO SONG accompaniment and drum volume .....	12	<b>VOICE LIST</b> .....	35
Mute the drums of DEMO SONG .....	12	<b>GM DRUM KIT LIST</b> .....	37
Adjusting DEMO SONG tempo .....	13	<b>DEMO SONG LIST</b> .....	39
<b>RECORD YOUR PERFORMANCE</b> .....	13		
Recording quickly .....	13		
Playing back the recorded performance .....	13		
<b>METRONOME</b> .....	14		
Adjusting the click .....	14		
<b>EDIT AND SAVE DRUM KIT VOICE</b> .....	15		
Edit the voice .....	15		
Save the voice .....	16		
<b>ADJUST PAD TRIGGER</b> .....	17		
Adjusting pad curve .....	18		
Adjust pad threshold .....	19		
Eliminate pad crosstalk .....	19		
Adjust pad sensitivity .....	19		
Adjust triggering mask time .....	19		
Adjust signal attenuation .....	20		

## ASSEMBLY GUIDE

1. Set up the drum stand.
2. Put the long cymbal tube/short cymbal tube/L shape pad rod into the drum stand.

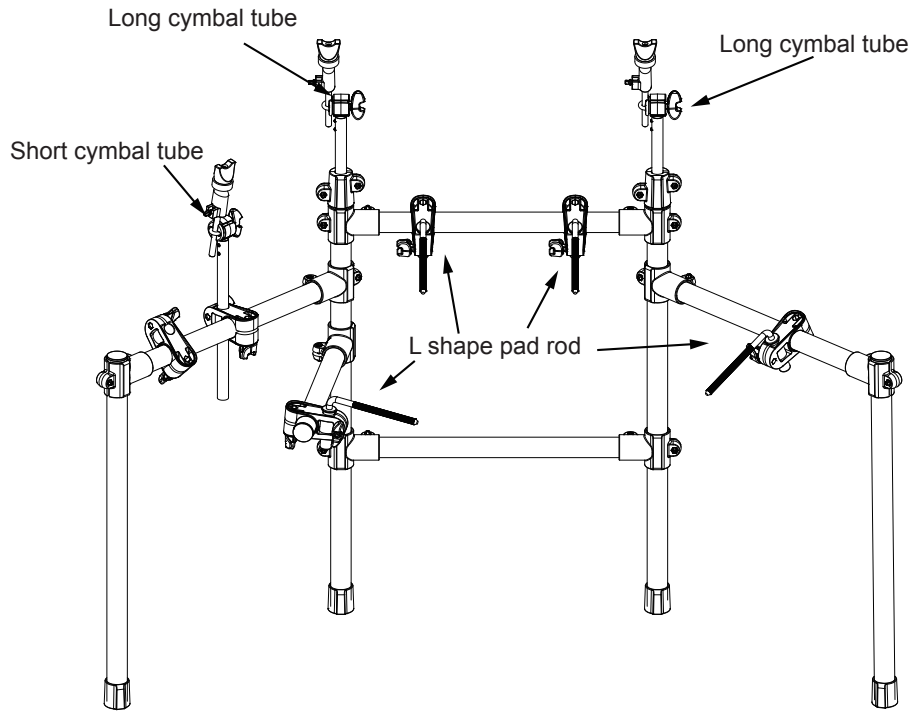

3. Put the pads/cymbal/module to the relative position.

Note No.	Standard name	Voice No.	Voice Name
57 – A3	Crash Cymbal 2	185	CRASH12
58 – A#3	Vibraslap	241	VSLP1
59 – B3	Ride Cymbal 2	209	RIDE8
60 – C4	Hi Bongo	242	HIBONGO
61 – C#4	Low Bongo	243	LOBANGO
62 – D4	Mute Hi Conga	244	MUTECONGA1
63 – D#4	Open Hi Conga	246	HICONGA1
64 – E4	Low Conga	248	LOCONGA1
65 – F4	High Timbale	250	HTIMBL1
66 – F#4	Low Timbale	252	LTIMBL1
67 – G4	High Agogo	254	HIAGOGO
68 – G#4	Low Agogo	255	LOAGOGO
69 – A4	Cabasa	256	CABASA
70 – A#4	Maracas	257	MARACS
71 – B4	Short Whistle	258	WHISTLE_S
72 – C5	Long Whistle	259	WHISTLE_L
73 – C#5	Short Guiro	260	SGUIRO
74 – D5	Long Guiro	262	GUIRO_L
75 – D#5	Claves	263	CLAVES
76 – E5	Hi Wood Block	264	WBLK_H
77 – F5	Low Wood Block	265	WBLK_L
78 – F#5	Mute Cuica	266	CUICA_M
79 – G5	Open Cuica	267	CUICA_O1
80 – G#5	Mute Triangle	269	MTRIANGLE
81 – A5	Open Triangle	270	OTRIANGLE
82 – A#5	Shaker	271	SHAKER1
83 – B5	Jingle Bell	273	JNGLBL
84 – C6	Bell Tree	274	BLTREE
85 – C#6	Castanets	275	CSTNTS1
86 – D6	Mute Surdo	277	SURDO_M
87 – D#6	Open Surdo	278	SURDO_O

## GM DRUM KIT LIST

Note No.	Standard name	Voice No.	Voice Name
27 – D#1	High Q	223	High Q
28 E1	Slap	224	SLAP
29 – F1	Scratch Push	225	SCRCH1
30 – F#1	Scratch Pull	226	SCRCH2
31 – G1	Sticks	227	STICK
32 – G#1	Square Click	228	SQCLCK
33 – A1	Metronome Click	229	CLICK
34 – A#1	Metronome Bell	230	BELL
35 – B1	Acoustic Bass Drum	1	KICK01
36 – C2	Bass Drum 1	6	KICK06
37 – C#2	Side Stick	55	SNRIM1
38 – D2	Acoustic Snare	49	SNARE23
39 – D#2	Hand Clap	231	CLAP1
40 – E2	Electric Snare	28	SNARE02
41 – F2	Low Floor Tom	160	TOML3
42 – F#2	Closed Hi Hat	72	CLHIHAT01
43 – G2	High Floor Tom	160	TOML3
44 – G#2	Pedal Hi-Hat	88	PDLHHT01
45 – A2	Low Tom	151	TOMM2
46 – A#2	Open Hi-Hat	104	OPNHHT01
47 – B2	Low-Mid Tom	144	TOMH2
48 – C3	Hi-Mid Tom	144	TOMH2
49 – C#3	Crash Cymbal 1	184	CRSH11
50 – D3	High Tom	144	TOMH2
51 – D#3	Ride Cymbal 1	206	RIDE5
52 – E3	Chinese Cymbal	193	CRSH20
53 – F3	Ride Bell	213	RDBELL4
54 – F#3	Tambourine	234	TAMBRINE
55 – G3	Splash Cymbal	191	CRSH18
56 – G#3	Cowbell	235	COWBELL1

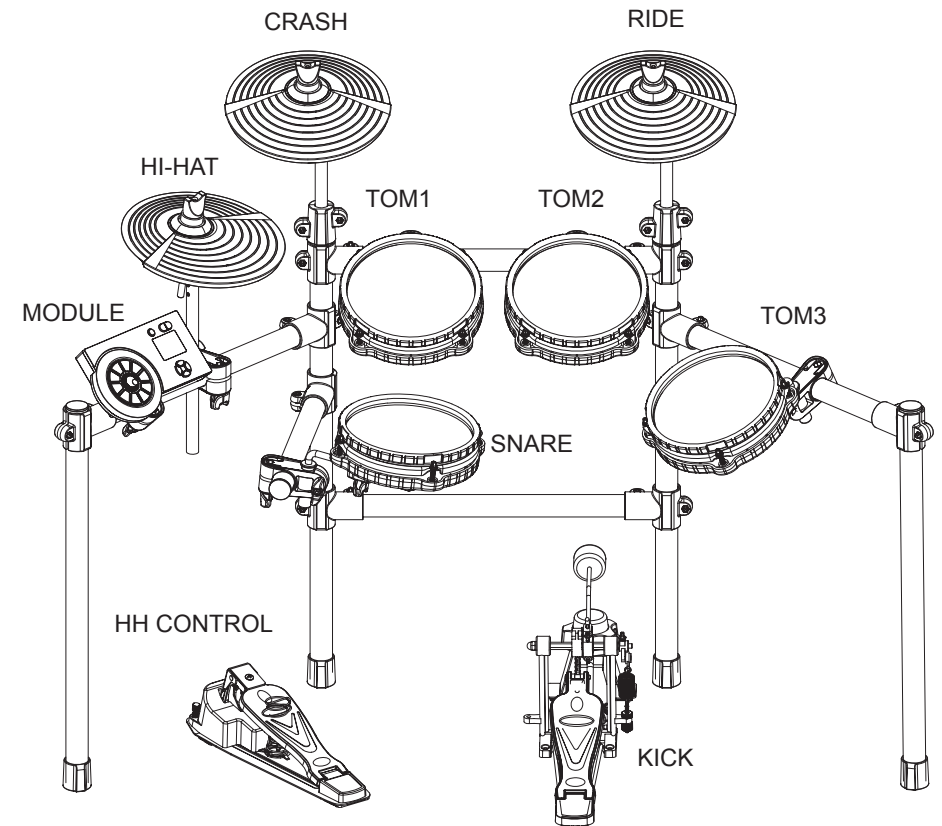

## CONNECTION

### Note

When connecting the pads and audio source box, turn off the power switch,  
Please, otherwise it will destroy the drum kit!

# FUNCTION BUTTON DESCRIPTION

## Front panel

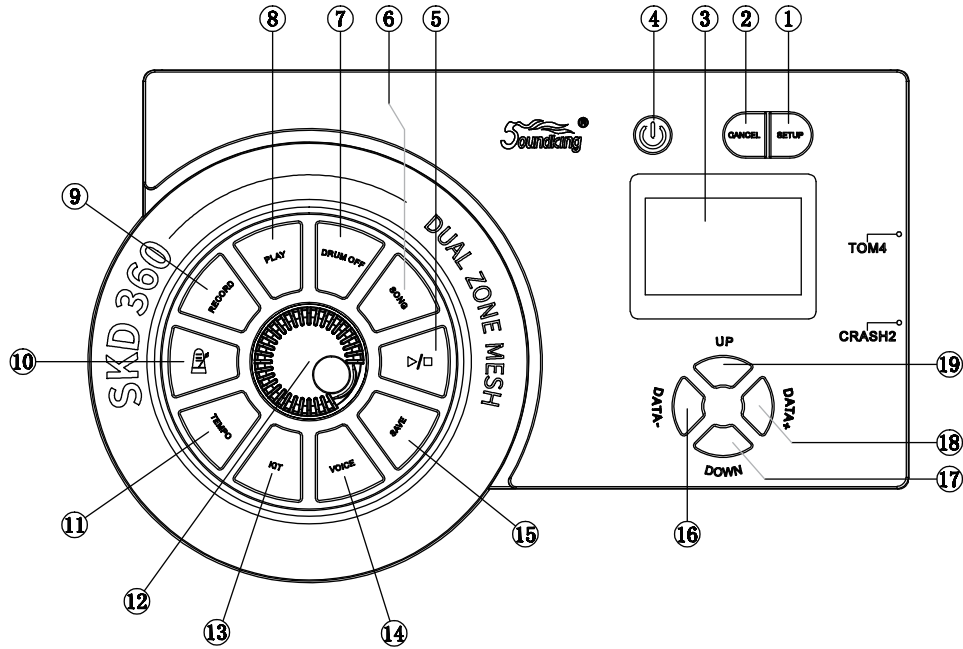

## Rear panel

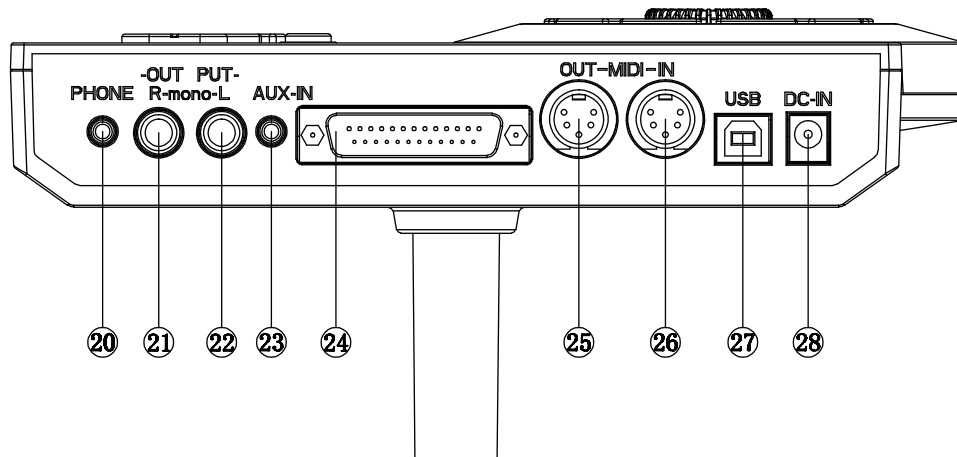

204	RIDE3
205	RIDE4
206	RIDE5
207	RIDE6
208	RIDE7
209	RIDE8
210	RDBELL1
211	RDBELL2
212	RDBELL3
213	RDBELL4
214	RDBELL5
215	RDBELL6
216	RDBELL7
217	ELCRASH1
218	ELCRASH2
219	ELCRASH3
220	ELCRASH4
221	ELCRASH5
222	ELCRASH6
<b>PERCUSSION</b>	
223	HI_Q
224	SLAP
225	SCRCH1
226	SCRCH2
227	STICK
228	SQCLCK
229	CLICK
230	BELL
231	CLAP1
232	CLAP2
233	CLAP3
234	TAMBRINE
235	COWBELL1
236	COWBELL2
237	COWBELL3
238	ELCRASH4
239	VSLAP
240	HIBONGO
241	LOBANGO
242	MUTECONGA1
243	MUTECONGA2
244	LOCONGA1
245	LOCONGA2
246	HTIMBL1
247	HTIMBL2
248	LTIMBL1
249	LTIMBL2
250	HIAGOGO
251	LOAGOGO
252	CABASA
253	MARACS
254	WHISTLE_S

255	LOAGOGO
256	CABASA
257	MARACS
258	WHISTLE_S
259	WHISTLE_L
260	SGUIRO
261	GUIRO S
262	GUIRO L
263	CLAVES
264	WBLK_H
265	WBLK_L
266	CUICA_M
267	CUICA_O1
268	CUICA_O2
269	MTRIANGLE
270	OTRIANGLE
271	SHAKER1
272	SHAKER2
273	JNGLBL
274	BLTREE
275	CSTNTS1
276	CSTNTS2
277	SURDO_M
278	SURDO_O
279	TLKNDML
280	TLKNDMH
281	TABLA1
282	TABLA2
283	SNAP
284	DJMB1
285	DJMB2
286	DJMB3
287	CAJON1
288	CAJON2
289	CAJON3
290	TMPNI1
291	TMPNI2
292	GONG_L
293	ELCLKH
294	ELCLKL
295	TAIKO
296	BELL
297	BAN
298	SIGU
299	DONG1
300	DONG2
301	GONG1
302	PIATIH
303	HGONG1
304	HGONG2
305	GONG2
306	GONG3

307	PIATIM
308	ESCRCH
309	ECLK
310	CIRCLE
311	DOWN
312	VOCAL1
313	VOCAL2
314	VOCAL3
315	VOCAL4
316	VOCAL5
317	VOCAL6
318	VOCAL7
319	VOCAL8
320	VOCAL9

# VOICE LIST

<b>KICK</b>	
1	KIT01
2	KIT02
3	KIT03
4	KIT04
5	KIT05
6	KIT06
7	KIT07
8	KIT08
9	KIT09
10	KIT10
11	KIT11
12	KIT12
13	KIT13
14	KIT14
15	KIT15
16	KIT16
17	KIT17
18	KIT18
19	KIT19
20	KIT20
21	KIT21
22	KIT22
23	KIT23
24	KIT24
25	KIT25
26	KIT26
<b>SNARE</b>	
27	SNARE01
28	SNARE02
29	SNARE03
30	SNARE04
31	SNARE05
32	SNARE06
33	SNARE07
34	SNARE08
35	SNARE09
36	SNARE10
37	SNARE11
38	SNARE12
39	SNARE13
40	SNARE14
41	SNARE15
42	SNARE16
43	SNARE17
44	SNARE18
45	SNARE19
46	SNARE20
47	SNARE21
48	SNARE22
49	SNARE23
50	SNARE24



51	SNARE25
52	SNARE26
53	SNARE27
54	SNARE28
55	SNRIM1
56	SNRIM2
57	SNRIM3
58	SNRIM4
59	SNRIM5
60	SNRIM6
61	SNRIM7
62	SNRIM8
63	ESNR1
64	ESNR2
65	ESNR3
66	ESNR4
67	ESNR5
68	ESNR6
69	ESNR7
70	ESNR8
71	ESNR9
<b>HIHAT</b>	
72	CLHIHAT01
73	CLHIHAT02
74	CLHIHAT03
75	CLHIHAT04
76	CLHIHAT05
77	CLHIHAT06
78	CLHIHAT07
79	CLHIHAT08
80	CLHIHAT09
81	CLHIHAT10
82	CLHIHAT11
83	CLHIHAT12
84	CLHIHAT13
85	CLHIHAT14
86	CLHIHAT15
87	CLHIHAT16
88	PDLHHT01
89	PDLHHT02
90	PDLHHT03
91	PDLHHT04
92	PDLHHT05
93	PDLHHT06
94	PDLHHT07
95	PDLHHT08
96	PDLHHT09
97	PDLHHT10
98	PDLHHT11
99	PDLHHT12
100	PDLHHT13
101	PDLHHT14

102	PDLHHT15
103	PDLHHT16
104	OPNHHT01
105	OPNHHT02
106	OPNHHT03
107	OPNHHT04
108	OPNHHT05
109	OPNHHT06
110	OPNHHT07
111	OPNHHT08
112	OPNHHT09
113	OPNHHT10
114	OPNHHT11
115	OPNHHT12
116	OPNHHT13
117	OPNHHT14
118	OPNHHT15
119	OPNHHT16
120	HOPNHHT01
121	HOPNHHT02
122	HOPNHHT03
123	HOPNHHT04
124	HOPNHHT05
125	HOPNHHT06
126	HOPNHHT07
127	HOPNHHT08
128	HOPNHHT09
129	LSHHT1
130	LSHHT2
131	LSHHT3
132	LSHHT4
133	LSHHT5
134	LSHHT6
135	LSHHT7
136	ELCHHT1
137	ELCHHT2
138	ELCHHT3
139	ELCHHT4
140	ELCHHT5
141	ELCHHT6
142	ELCHHT7
<b>TOM</b>	
143	TOMH1
144	TOMH2
145	TOMH3
146	TOMH4
147	TOMH5
148	TOMH6
149	TOMH7
150	TOMM1
151	TOMM2
152	TOMM3

153	TOMM4
154	TOMM5
155	TOMM6
156	TOMM7
157	TOMM8
158	TOML1
159	TOML2
160	TOML3
161	TOML4
162	TOML5
163	TOML6
164	TOML7
165	TOML8
166	TOML9
167	TOME1
168	TOME2
169	TOME3
170	TOME4
171	TOME5
172	TOME6
173	TOME7
<b>CYMBAL</b>	
174	CRSH01
175	CRSH02
176	CRSH03
177	CRSH04
178	CRSH05
179	CRSH06
180	CRSH07
181	CRSH08
182	CRSH09
183	CRSH10
184	CRSH11
185	CRSH12
186	CRSH13
187	CRSH14
188	CRSH15
189	CRSH16
190	CRSH17
191	CRSH18
192	CRSH19
193	CRSH20
194	CRSH21
195	CRSH22
196	CRSH23
197	CRSH24
198	CRSH25
199	CRSH26
200	CRSH27
201	CRSH28
202	RIDE1
203	RIDE2

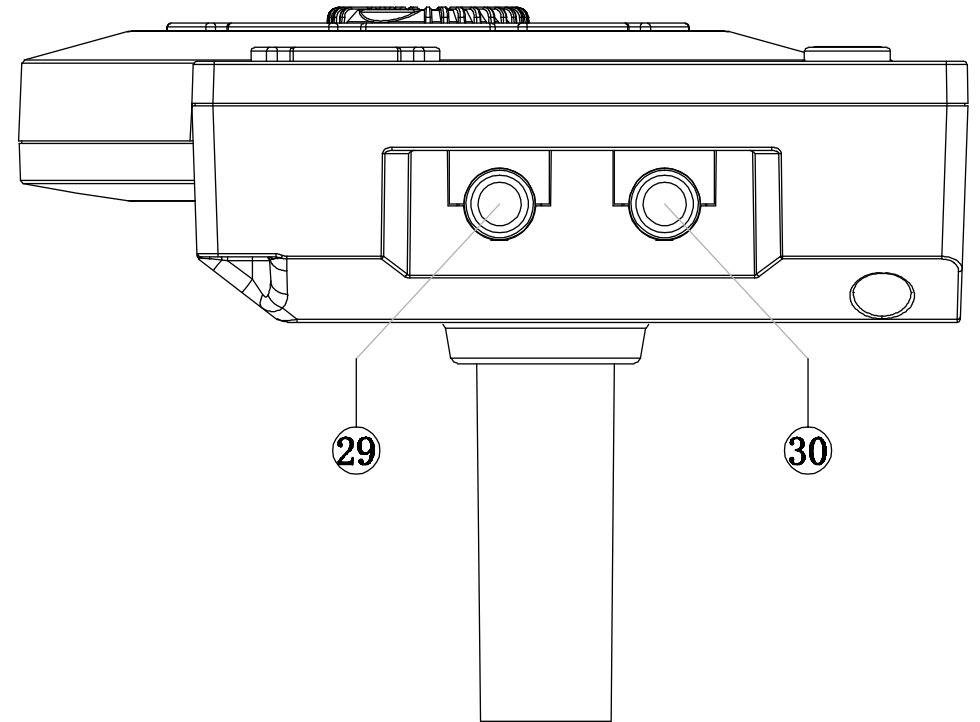
## Side Panel



NO.	NAME	DESCRIPTION
1	SETUP	Enter the menu setting interface
2	CANCEL	Exit the current operation and return to the previous interface
3	LCD display	LCD display: content of menu
4	POWER	Power switch (long press to turn off)
5		Start/stop DEMO SONG playing
6	SONG	Enter the DEMO SONG setting interface
7	DRUM OFF	Drum track playback control, LED lights up means off and goes off means on
8	PLAY	Press once to play the recording sound/press the second time to stop
9	RECORD	Enter the recording waiting state, hit any pad to start the recording , button light flashing
10		Metronome play switch
11	TEMPO	Quick access to speed adjustment
12	MASTER LEVEL	Adjust the master volume
13	KIT	Quick access to the KIT home page
14	VOICE	Enter the voice page
15	SAVE	Save current settings
16	DATE-	Editor the parameters
17	DOWN	Next menu options
18	DATE+	Editor the parameters
19	UP	Former Menu options
20	PHONE	Stereo headphone output connector
21	R OUTPUT	Audio output of right channel and LOOUTPUT constitute stereo output
22	L(MONO) OUTPUT	Left channel output, can be separately connected to the drum amplifier via mono - channel cable
23	AUX IN	Connect to a digital audio player or as listening input for live performance
24	TRIGGERS IN	Drum signal input port
25	MIDI IN	Connect to other MIDI output interfaces with MIDI devices
26	MIDI OUT	Connect to other MIDI input interfaces with MIDI devices
27	USB	Connect with PC connector(MIDI input/output or software update via USB)
28	DC IN	Power adapter port: 12V 1A
29	CRASH2	Connect with CRASH2
30	TOM4	Connect with TOM4

## DRUM KIT LIST

No.	Name	No.	Name
KIT01	ROCK	KIT20	COUNTRY
KIT02	FUNK/POP	KIT21	ORCH
KIT03	JAZZ	KIT22	SONGGU
KIT04	LATIN	KIT23	WORLD
KIT05	DANCE	KIT24	PERC.1
KIT06	POP1	KIT25	PERC.2
KIT07	POP2	KIT26	USER01
KIT08	POP3	KIT27	USER02
KIT09	HARD RCK	KIT28	USER03
KIT10	METAL	KIT29	USER04
KIT11	FUNK1	KIT30	USER05
KIT12	FUNK12	KIT31	USER06
KIT13	HIP-HOP	KIT32	USER07
KIT14	FUSSION	KIT33	USER08
KIT15	BLUES	KIT34	USER09
KIT16	CUBAN	KIT35	USER10
KIT17	BRUSH	KIT36	USER11
KIT18	ELE1	KIT37	USER12
KIT19	ELE1		



## AUDIO SOURCE SPECIFICATIONS

**POLYPHONY:** 64

**Display:** lattice 128 X 64 LCD

**VOICE:** 320 drum and other percussion voices + 128 kinds of GM music tone

**DRUM KITS:** 25 preset drum kits + 12 user drum kits

**Effect:**

- 1) 2 stage EQ setting (high/low) /GAIN adjustment
- 2) Reverb setting, 6 reverberation field Settings (room 1, room 2, room 3, hall 1, hall 2, plate), reverberation size 0-4/ reverberation time value 0-127

**SEPUENCER:**

- 1) Single track recording 1000 notes
- 2) Normal mode: 20 preset song

**TEMPO FUNCTION:**

- 1) Tempo tone:3 kinds
- 2) Adjustable range:30--250
- 3) Tempo:1/2-9/8

**CONNECTION:**

Headphone stereo output (1/8")、AUX INPUT stereo port (1/8")

Audio output interface LMONO OUT(1/4")、R OUT(1/4")、

Sensor interface (D-SUB 25P)

MIDI IN/MIDI OUT Interface (standard 5-pin port)

USB Data interface (USB B-type interface)

Extension:CRASH2、TOM4(1/4")

Battery power supply interface

\*\*\* The specification is subject to change without prior notice. \*\*\*

## CONNECT WITH EXTERNAL DEVICES

Connect to audio system or amplifier

When connecting with audio system or drum amplifier, connect one end of the audio cable with the module OUTPUT: R L/mono, and the other end with the audio system or drum amplifier.

Note:

1. Plug into L/mono connector when connecting with mono audio device.
2. Plug into L/mono and R connectors when connecting with stereo device. The output volume can be adjusted via the master volume knob on the module or that on the audio device.

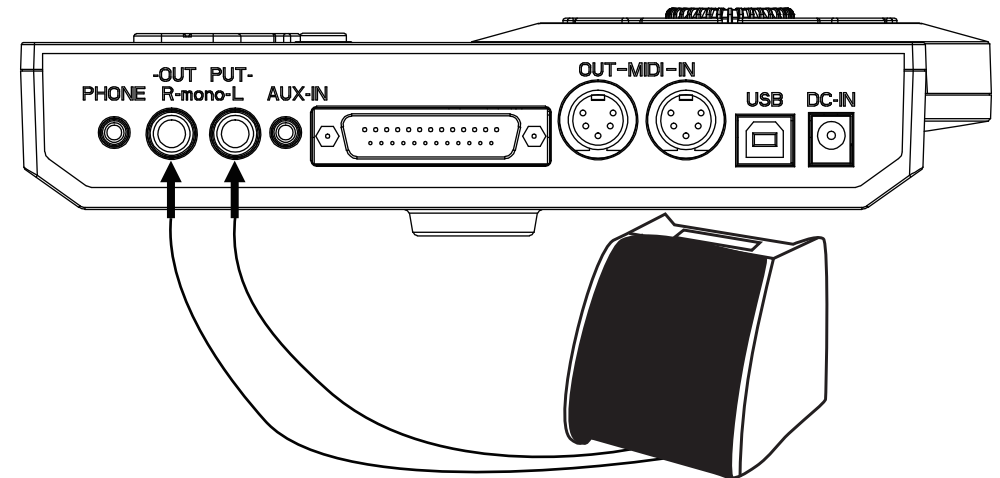

Connect to headphones

The module has 1/8" stereo headphone connector, the volume is controlled by the master volume knob on the module

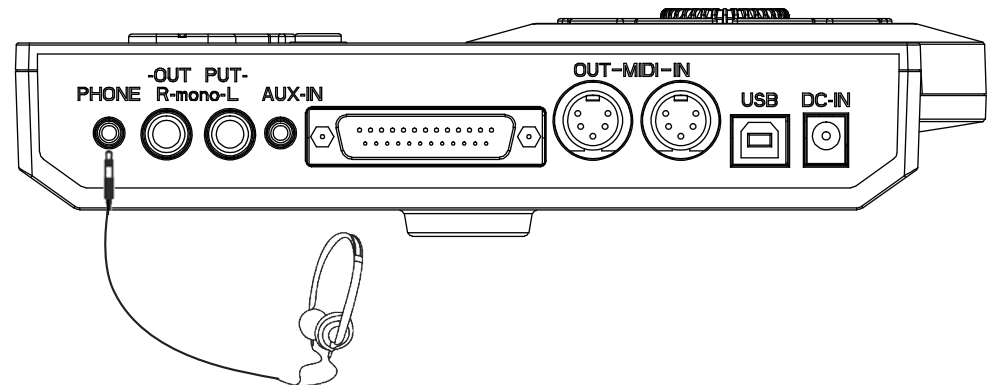

### Connect to MP3 or CD player

Connect the output of MP3 or CD player or other audio sources with AUX. IN connector. The volume can be adjusted by the master volume control knob on the module. The input signal can be mixed with the drum signal, strike the pads according to the rhythm of the input signal.

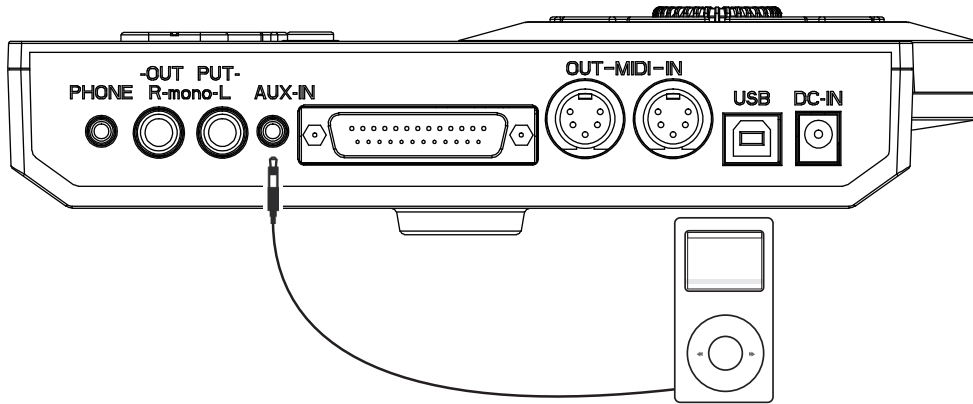

### Connect with computer

1. Connect the computer via USB cable when it's powered off
2. Turn on the computer and then turn on the device, when the connection is successful, you can receive and send MIDI information.

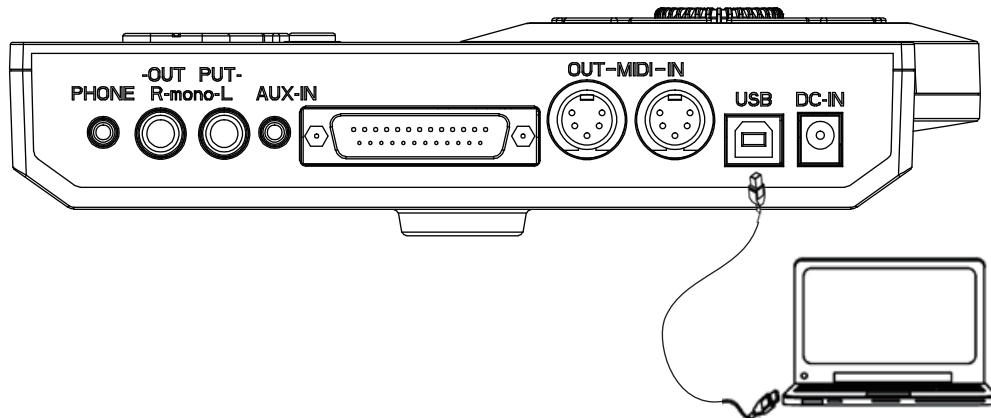



## TROUBLE SHOOTING

Problem	Reason or solution
No sound / sound is too low	1. Make sure the volume knob is set correctly and adjust the volume knob
	2. Check whether the audio cable between the audio source and the power amplifier or other playback equipment is connected correctly. Replace the cable to test.
	3. If you are connecting to the audio device through the mixer, please insert a good earphone into the headphone output jack of the audio source. If there is sound, please check whether the cable is normal, the Settings and connections of the mixer and audio equipment normal?
No sound on the external drum pad	1. Please make sure that the connecting wire between the drum pad and the host machine is connected correctly and in place.
	2. Check whether setting "LOCAL" to "OFF". If setting to "OFF", there is no sound output on the drum pad.
	3. Check whether the corresponding drum volume is set to 0.
No sound on the external drum pad	Whether the metronome volume is 0
No sound on DEMO SONG	Please make sure the volume of DEMO SONG is not 0
There is no sound output connected to MIDI communication devices	1. Check whether the USB cable used to connect is damaged.
	2. Verify whether the communication channel is set correctly. The communication channel set by the audio source is 10 channels by default. If the audio source is set to other channels, other MIDI devices should also be set to corresponding channels.

## SYSTEM SOFTWARE UPDATE

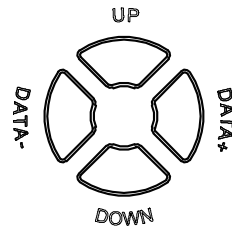
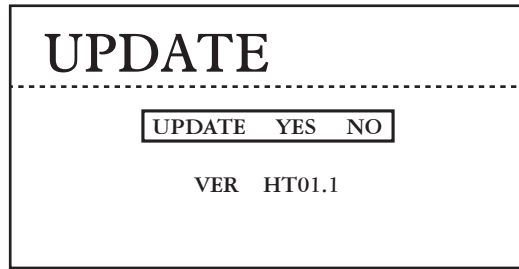
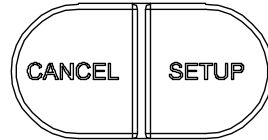
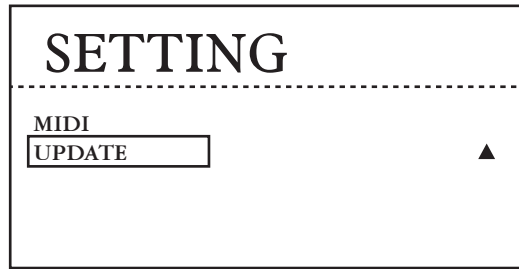
Press **【SETUP】** to enter SETTING menu, and press **【DOWN】** to select DRUM OPTION, then press **【SETUP】** to enter UPDATE menu



Connect the module to the computer via the USB cable before operation, then select Yes by pressing **【DATE+】** or **【DATE-】** in the UPDATE option and press **【SETUP】** again. The system will have USB devices identified  , And on my computer in the form of a USB flash drive  . You can double click the left mouse button to open, to update the program file (file name) copy and paste in the U disk, you can complete the software upgrade.

Note: The upgrade file can be downloaded from the company's official website, or consult relevant sales staff. The correct file name is "A005000.bin"  **A005000.bin** . Do not turn off the mainframe power during the upgrade process. Keep the mainframe power supply stable and have no other operation.

## Connect to computer via MIDI

MIDI IN: Receive MIDI signals from external MIDI devices or computers  
MIDI OUT: Sends pads signal to external MIDI device or computer

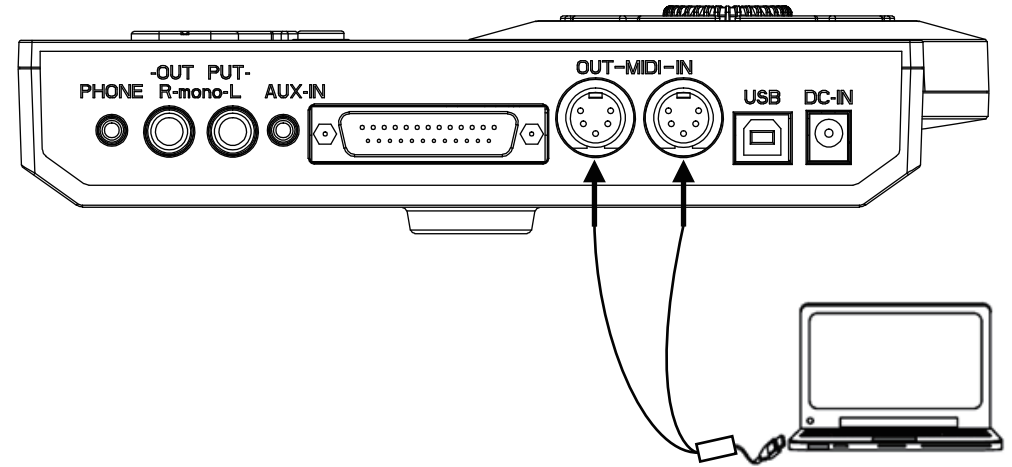

## Connect the MIDI keyboard via the MIDI port

MIDI-IN/OUT: If external keyboard or MIDI device are used to control the drum, it needs MIDI cable one end connecting with MIDI IN of the module, and other end with MIDI OUT of the MIDI keyboard. This drum is used as audio source. The connection is as follows:

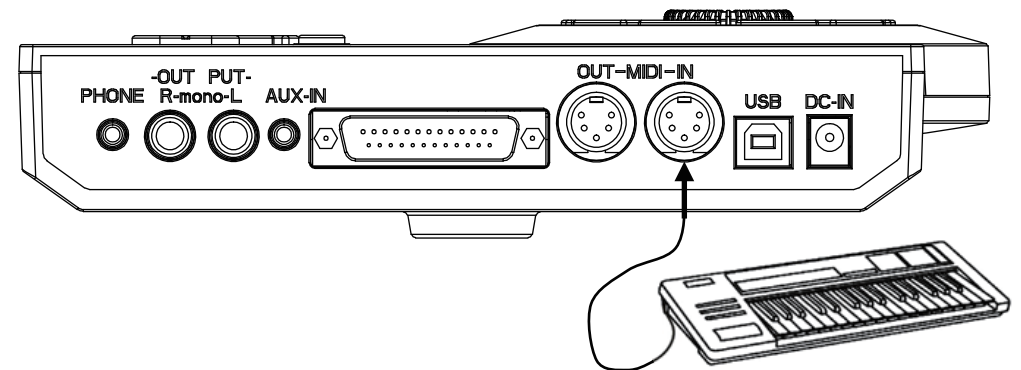

## Connect with power supply

1. Plug the power adapter into DC IN connector
2. Make sure all drum pads are connected, turn the master volume on the drum module to the minimum, and then press the power button down. At which point the display will light up and enter the drum set menu.

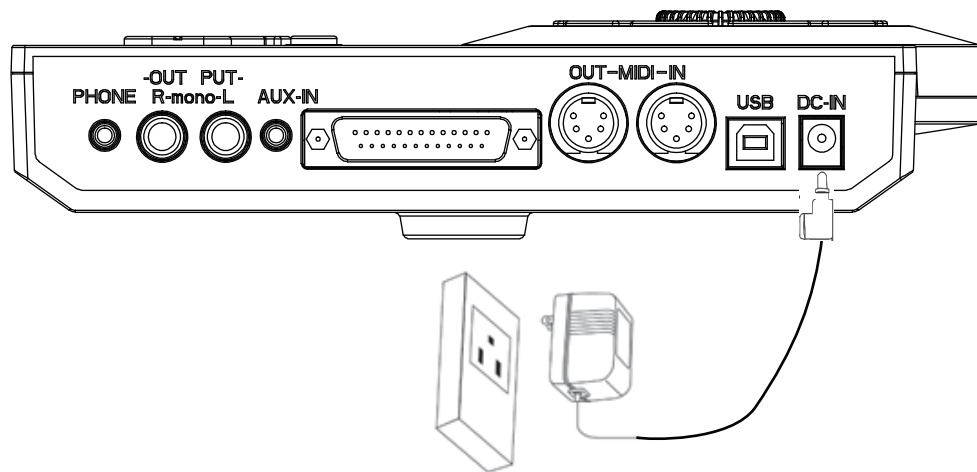

## BASIC OPERATION

### Select a drum kit

After powering up, the display should look like the following figure (KIT01 ROCK)

<b>KIT 01</b>		<b>ROCK</b>	
CLICK	4/4		
TEMPO	100		
SONG	01		
DRUM	OFF		

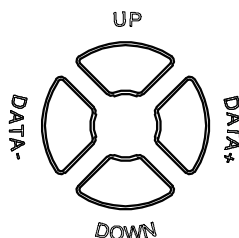

Drum sets can be switched between **【DATA+】** and **【DATA-】**. 37 sets of drum kits in all.

25 set of preset drum kits: KIT01---KIT25

12 set of user drum kits: KIT26---KIT37

## MIDI list

FUNCTION		TRANSMITTED	RECOGNIZED	REMARKS
BASIC CHANNEL	DEFAULT CHANGED	10 Ch 1-16	1-16 1-16	
MODE	DEFAULT MESSAGES ALTERED	x x *****	x x *****	
NOTE MEMBER:	TRUE VOICE	0-127 *****	0-127 0-127	
VELOCITY	NOTE ON NOTE OFF	O 9nH,V=1-127 X (9nH,V=0)	o o	
AFTER TOUCH	KEY'S CH'S	x x	x x	
PITCH BEND		x	x	
CONTROL CHANGE		0 x 1 x 5 x 6 x 7 x 10 x 11 x 64 x 65 x 66 x 67 x 80 x 81 x 91 x 93 x 120 x 121 x 123 x	o o o o o o o o o o o o o o o o o o	BANK SELECT MODULATION PORTAMENTO TIME DATA ENTER VOLUME PAN EXPRESSION SUSTAIN PEDAL PORTAMENTO ON/OFF SOSTENUTO PEDAL SOFT PEDAL REVERB PROGRAM CHROUS PROGRAM REVERB LEVEL CHROUS LEVEL ALL SOUNDS OFF RESET ALL CONTROLLERS ALL NOTES OFF
PROGRAM CHANGE	TRUE NUMBER	o *****	o 0-127	
SYSTEM EXCLUSIVE		x	o	
SYSTEM COMMON	: SONG POSITION : SONG SELECT : TUNE	x x x	x x x	
SYSTEM REAL TIME	: CLOCK : COMMANDS	o o	x x	START AND STOP ONLY
AUX MESSAGE	: LOCAL ON/OFF : ALL NOTES OFF : ACTIVE SENSING : RESET	x x o x	x x x x	

Default factory setting as below:

TRIGGER	MIDI NOTE	TRIGGER	MIDI NOTE	TRIGGER	MIDI NOTE
KICK	36	TOM2	45	TOM4 RIM	39
SNARE	38	TOM2 RIM	47	CRASH	49
SANRE RIM	37	TOM3	43	HI-HAT CTRL	44
TOM1	48	CRASH2	57		
RIDE	51	HI-HAT C	42		
HI-HAT O	46	TOM3 RIM	58		
TOM1 RIM	50	TOM4	41		

#### Used as an audio source device

When connected with external MIDI keyboard or sequencer through MIDI OUT or USB cable, the device can receive its MIDI output signal, and then the device can play OUT the valid signal. The output tone changes with the switch of drum kit. This equipment has most GM drum kit tone. Users can build their own USER drum kit if necessary. Other MIDI support and limitations are described in the MIDI list

#### Playing the pads

Similar to an acoustic drum kit, the digital drum responds differently to various playing techniques and dynamics. All the pads senses the striking force. And some voices change tone depending on the striking force.

The digital drum pad detects head and rim shorts (rim shorts are different from the pad shorts)  
Note:

- 1.SNARE and TOM1-TOM3 are dual zone.
- 2.All pads are single zone, CRASH and RIDE have the choke, e.g. hit the cymbal then hold the rim to choke (stop) the sound.
- 3.SNARE delivers one sound when hit the pad rim strongly.

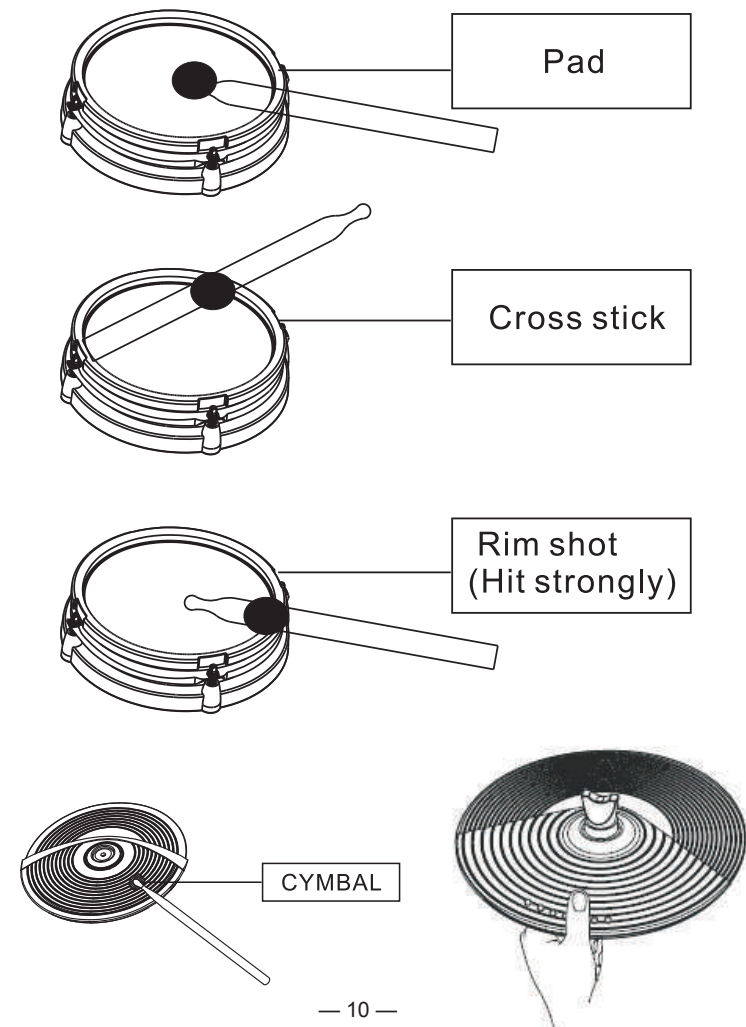

## HI-HAT demonstration

**The Hi-Hat:** sound varies depending on the position of the Hi-Hat pedal:

**Open Hi-Hat:** strike the Hi-Hat pad without pressing the pedal.

**Half-open Hi-Hat:** strike the Hi-Hat pad with the pedal pressed but not completely down.

**Close Hi-Hat:** strike the Hi-Hat pad with the pedal pressed completely down.

**Hi-Hat pedal close:** press the pedal completely down without striking the pad.

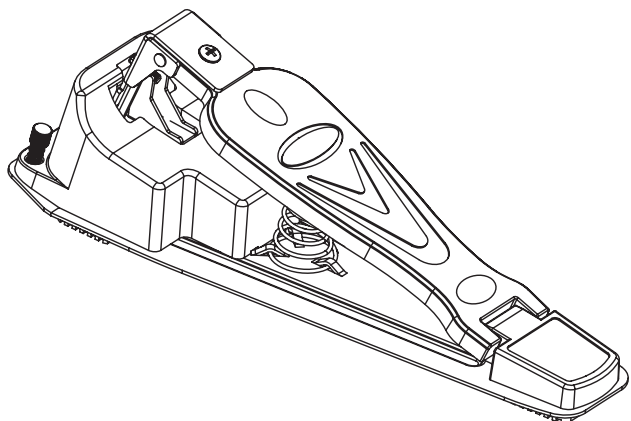

## DEMO SONG

### Play and switch the DEMO SONG

Press the **▶|■** to play DEMO SONG, press again to stop. Use **【DOWN】** to select the SONG, then press **【DATE+】** or **【DATE-】** to switch (refer to DEMO SONG LIST for DEMO SONG)

<b>KIT 01</b>	<b>ROCK</b>
CLICK	4/4
TEMPO	100
SONG	01
DRUM	OFF

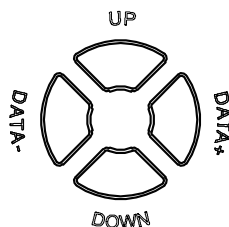

## MIDI connection

**MIDI IN:** inputs MIDI signal when connecting with external MIDI device

**MIDI OUT:** outputs MIDI signal when connecting with external MIDI device

**USB:** standard USB2.0 interface. It can be connected to any MIDI device or PC with a standard USB driver, and the corresponding driver is included in the general operating system, so there is no need for repeated installation. Can be compatible with common computer operating systems such as: XP, Win7, Vista, Mac OSX, etc. (USB is only used for MIDI connection).

Note: When USB connects with PC, all MIDI data will be received and transmitted via USB

## Connect with external audio device

This device automatically connects via channel 10 transfers drum signal to other MIDI device including notes, forces, pedal performance, etc.

Note: Song playback data and metronome notes are not transferred.

Record your performance with external sequencer

- 1.Connect with external sequencer or PC via MIDI OUT and IN for playback or USB interface
- 2.Use the sequencer or the software to set channel 10 as a device to start recording.
- 3.Play the drum pads
- 4.Stop performance and recording. Playback the recording

Setting MIDI note number to be transferred/received by each pad

- 1.Press VOICE button to enter the VOICE menu.
- 2.Strike the relative pad, use **【UP】** or **【DOWN】** to select MIDI KEY
- 3.Use **【DATE+】** or **【DATE-】** to adjust the MIDI value for a pad.
- 4.Press save button to save USER drum kit.

## MIDI SETTING

This device is compatible with various MIDI devices. When it is used as trigger device or audio source, it is compatible with GM standard, and can be used with most sequencer software.

Press **【SETUP】** to enter SETTING menu, and press **【DOWN】** to select MIDI option, then press **【SETUP】** to enter MIDI menu

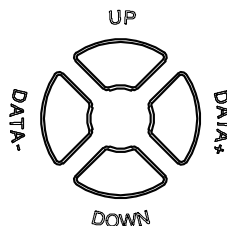
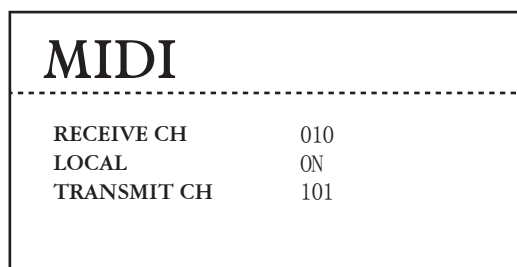
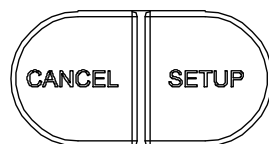
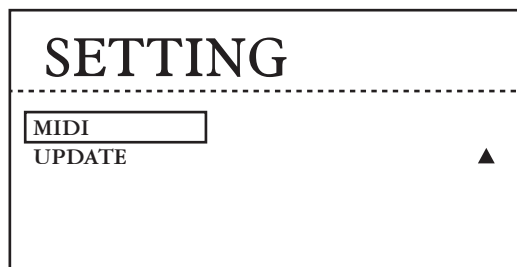

RECEIVE CH: Receive channel selection, default is channel 10

LOCAL: Local control to control the connection between the trigger and the drum module

ON: The drum pad is connected with the internal sound module, and the drum pad is tapped to produce sound, which defaults to ON

OFF: The drum pad is disconnected from the internal sound module, and the drum pad does not sound

TRANSMIT: Output channel selection, default is channel 10

## Adjusting DEMO SONG accompaniment and drum volume

Press **【SONG】** to enter SONG setting menu, after entering, use **【DATE+】** or **【DATE-】** to select the preset DEMO SONG.

Press **【DOWN】** to select ACC VOLUME, use **【DATE+】** or **【DATE-】** to adjust DEMO SONG accompaniment volume.

Press **【DOWN】** to select DRUM VOLUME, use **【DATE+】** or **【DATE-】** to adjust drum volume.

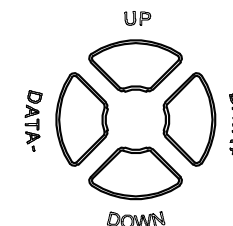
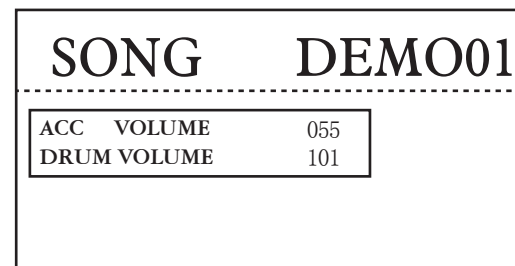

## Mute the drums of DEMO SONG

1. Press **【DRUM OFF】** can quickly ON or OFF the drum volume of DEMO SONG
2. Use **【UP】** or **【DOWN】** key to select DRUM OFF, ON or OFF the drum volume of DEMO SONG by **【DATE+】** or **【DATE-】** key.

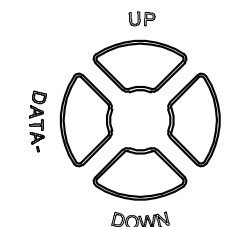
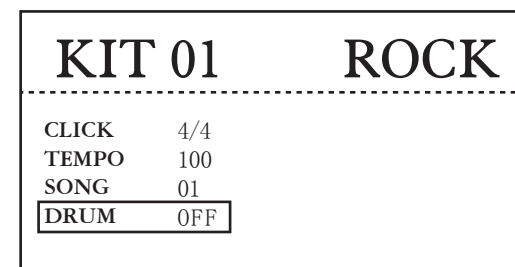

### Adjusting DEMO SONG tempo

1. Press **【TEMPO】** to select TEMPO, use **【DATE+】** or **【DATE-】** to adjust DEMO SONG tempo.
2. Use **【UP】** or **【DOWN】** on home page to select TEMPO, then adjust the tempo by **【DATE+】** or **【DATE-】**

<b>KIT 01</b>		<b>ROCK</b>	
CLICK	4/4		
TEMPO	100		
SONG	01		
DRUM	OFF		

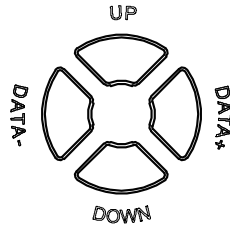

### RECORD YOUR PERFORMANCE

#### Recording quickly

Press **【RECORD】** then **【RECORD】** LED lights up, strike any pad to start recording and the LED start flashing. Press **【RECORD】** again to stop recording and the LED lights off.

#### Playing back the recorded performance

Press **【PLAY】** then **【PLAY】** LED lights up, and it plays the recorded performance, press **【PLAY】** again to stop playing.

If you are unsatisfied with the recorded performance, press **【RECORD】** to record once again.

Note: it can record the performance but can not save. This means the recorded performance will replace the former recorded performance

<b>DRUM OPTION</b>	
TOM RIM	ON
SNARE RIM	ON
HIHATTYPE	HH
HIHA SENS	08
JICK TYPE	P/H

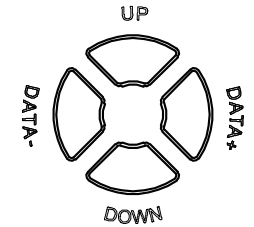

HIHATTYPE: pedal type selection, default: HH (standard equipped: pedal type)

HIHATTYPE: simulate hi-hat, default: HHS

In the HIHAT SENS option, press **【DATE+】** or **【DATE-】** to adjust the velocity slope of HI HAT.

#### Kick sensor type

Press **【SETUP】** to enter SETTING menu, and press **【DOWN】** to select DRUM OPTION, then press **【SETUP】** to enter KICK TYPE menu

<b>SETTING</b>	
VOICE	
PAD TRGGER	
EFFECT	
DEFAULT SETTING	
DRUM OPTION	▼

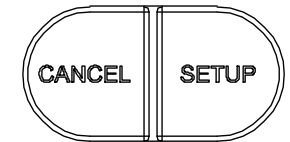

<b>DRUM OPTION</b>	
TOM RIM	ON
SNARE RIM	ON
HIHATTYPE	HH
HIHAT SENS	08
KICK TYPE	P

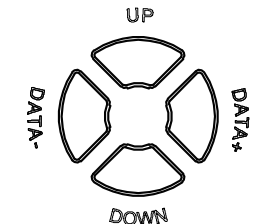

In the KICK TYPE option, press **【DATE+】** or **【DATE-】** to switch KICK type

KICK TYPE: pedal type, default: P

KICK TYPE: hammer type, default: H (standard equipped)



## SELECT TRIGGER

### Tom and snare rim trigger setting

Press **【SETUP】** to enter SETTING menu, and press **【DOWN】** to select DRUM OPTION, then press **【SETUP】** to enter DRUM OPTION menu.

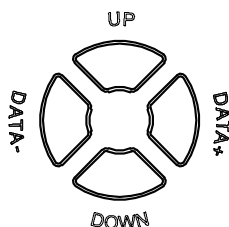
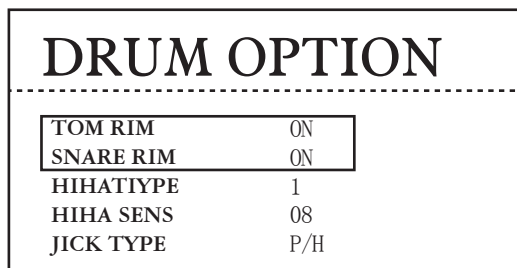
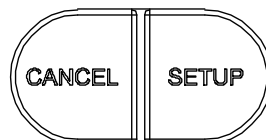
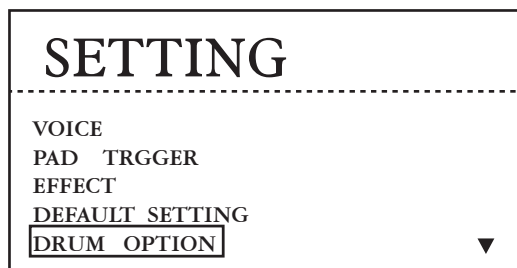

In the TOM RIM or SNARE RIM option, press **【DATE+】** or **【DATE-】** to switch ON or OFF. Rim trigger is valid in the ON state and invalid in the OFF state.

### HI-HAT trigger setting

Press **【SETUP】** to enter SETTING menu, and press **【DOWN】** to select DRUM OPTION, then press **【SETUP】** to enter DRUM OPTION menu.

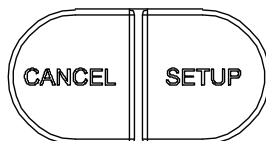
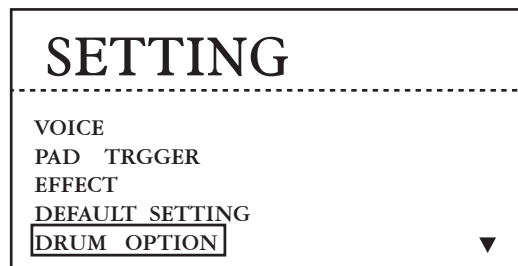

## METRONOME

User can use the **【】** button to turn on/off metronome, When the metronome is turned on, the first beat of the metronome button will be light up red, the other beats will be light up green and the cycle lights up

### Adjusting the click

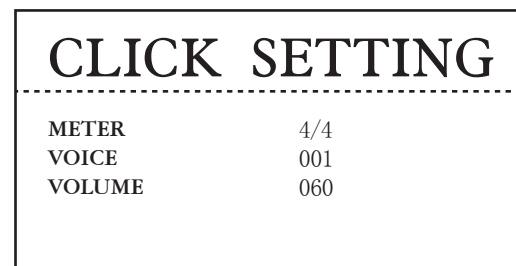

Long press **【】** to enter the CLICK SETTING page.  
 METER: 1/2、 2/2、 3/2、 4/2、 5/2、 6/2、 7/2、 8/2、 9/2、 1/4、 2/4、 3/4、 4/4、 5/4、 6/4、 7/4、 8/4、 9/4、 1/8、 2/8、 3/8、 4/8、 5/8、 6/8、 7/8、 8/8、 9/8  
 VOICE: user can adjust the voice (001-004);  
 VOLUME: user can adjust the voice volume (000-127)

## EDIT AND SAVE DRUM KIT VOICE

### Edit the voice

Press **【SETUP】** to enter SETTING page, press **【SETUP】** to enter VOICE sub menu.

SETTING	
VOICE	
PAD	TRIGGER
EFFECT	
DEFAULT	VSEEING
DRUM	OPTION

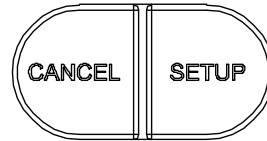

VOICE	KICK
001	KICK01
VOLUME	111
PAN	036
MIDI KEY	038
REVERB	0-10

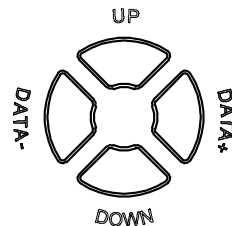

On the right side of the title bar in the VOICE menu, the current name of the drum to be adjusted will be displayed. You can switch it by hitting the drum to be adjusted.

The sound number and the voice name are displayed below the title bar, and use **【DATE+】** and **【DATE-】** to select the voice you want. As shown below:

VOICE	KICK
001	KICK01
VOLUME	111
PAN	036
MIDI KEY	038
REVERB	0-10

DEFAULT SETTING	
RESTORE	USER001
RESTORE	TRIGGER
RESTORE	ALL

SETUP FOR YES

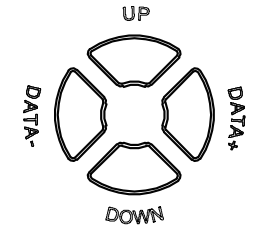

Press **【SETUP】** on RESTORE TRIGGER to start restore, the system will show RESTORE TIGGER SUCCEED after completion.

### All parameters restore factory settings

Press **【SETUP】** to enter SETTING menu, and press **【DOWN】** to select RESTORE ALL, then press **【SETUP】** to enter RESTORE ALL menu

SETTING	
VOICE	
PAD	TRIGGER
EFFECT	
DEFAULT SETTING	
DRUM	OPTION

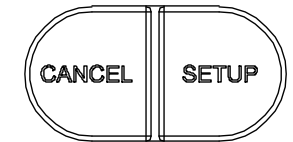

DEFAULT SETTING	
RESTORE	USER001
RESTORE	TRIGGER
RESTORE	ALL

SETUP FOR YES

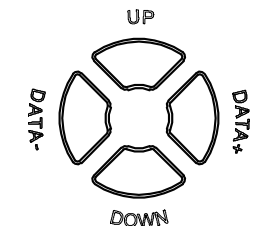

Press **【SETUP】** on RESTORE ALL to start restore. It shows RESTORE ALL SUCCEED after completion.

Restore a single user drum kit to its default settings, select drum kit, press **【ENTER】** to restore, the system will show a restoration query, press **【ENTER】** again to start restoration. After restoration is completed, the system will prompt that restoration is completed.

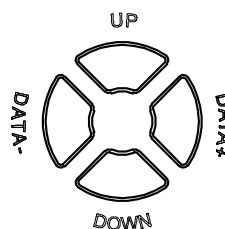
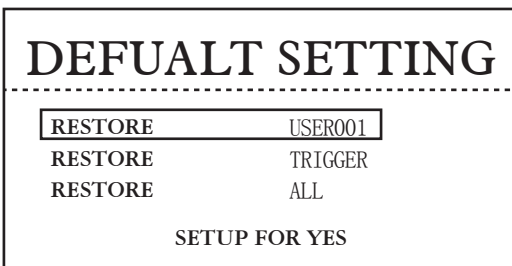
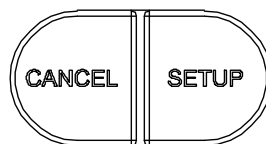
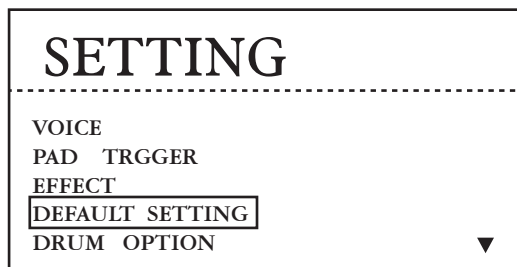

Note: Only one drum kit can be restored at a time (the relevant PAD TRIGGER Settings cannot be restored)

Drum pad triggering parameters restore factory settings

Press **【SETUP】** to enter SETTING menu, and press **【DOWN】** to select RESTORE TRIGGER, then press **【SETUP】** to enter RESTORE TRIGGER menu.

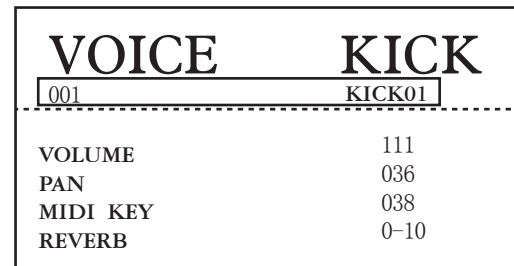
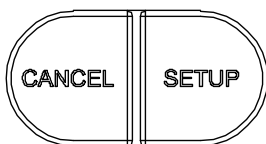
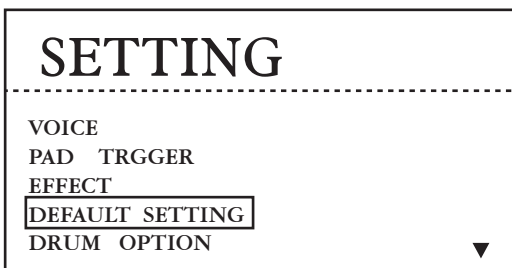

1. VOLUME: Adjust voice volume
2. PAN: Adjust the pan of L/R channel
3. MIDI KEY: Adjust MIDI output pitch value(000-127)
4. REVERB: Adjust reverberation

Press **【UP】** and **【DOWN】** to switch settings, press **【DATE+】** or **【DATE-】** to adjust the parameters. All parameters in the VOICE menu will be saved in real time after being adjusted. If you need to restore the default value of the system, you can simultaneously press **【DATE+】** and **【DATE-】** buttons for more than 3 seconds to reset.

Save the voice

Press **【SAVE】** after finish the voice adjustment, press **【DATE+】** or **【DATE-】** to select the user drum kit you want to save, press **【SAVE】** again to save the corresponding user drum kit.

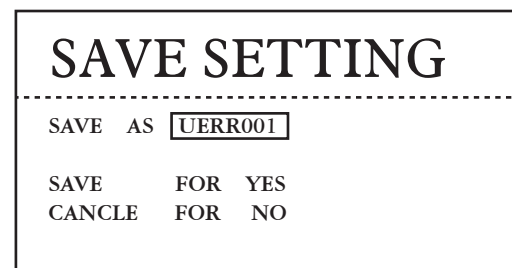

## ADJUST PAD TRIGGER

Press **【SETUP】** to enter SETTING menu, press **【DOWN】** to select PAD TRIGGER, press **【SETUP】** again to enter TRIGGER sub-menu.

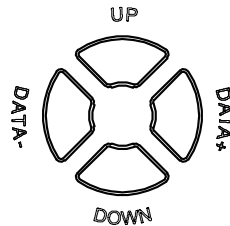
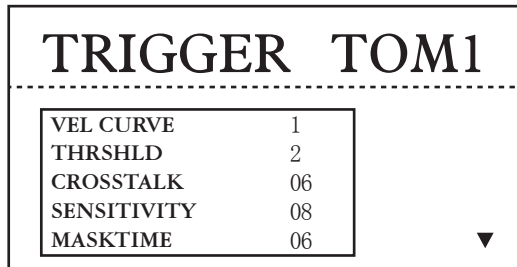
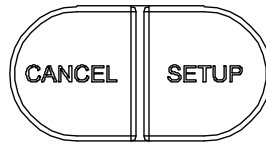
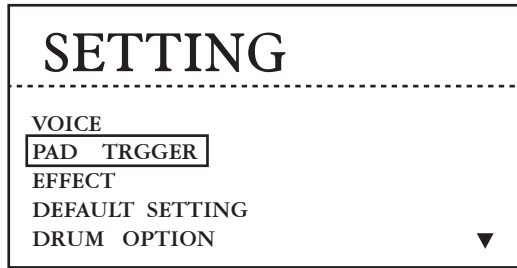

On the right side of the title bar in the VOICE menu, the current name of the drum to be adjusted will be displayed. You can switch it by tapping the drum to be adjusted.

Note: Press **【UP】** and **【DOWN】** to switch settings, press **【DATE+】** or **【DATE-】** to adjust the parameters. All parameters in the drum pad trigger menu will be saved in real time after being adjusted. If you need to restore the default value of the system, you can simultaneously press **【DATE+】** and **【DATE-】** buttons for more than 3 seconds to reset.

## Reverb setting

Press **【SETUP】** to enter SETTING menu, press **【DOWN】** to select EFFECT, then press **【SETUP】** again to enter EFFECT menu.

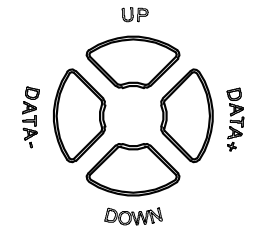
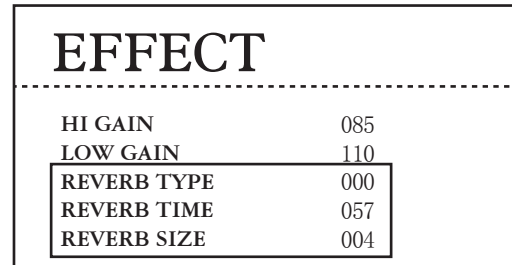
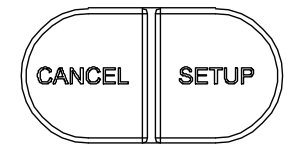
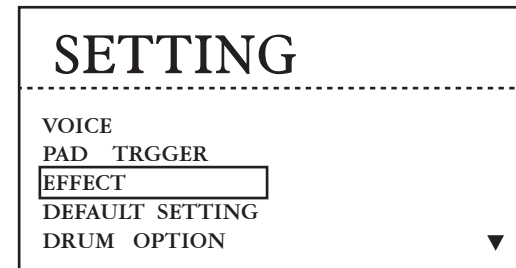

REVERB TYPE: adjust the reverb type. Press **【DATE+】** or **【DATE-】** to adjust parameter.

REVERB TIME: adjust the reverb delay time. Press **【DATE+】** or **【DATE-】** to adjust parameter.

REVERB SIZE: adjust the reverb size. Press **【DATE+】** or **【DATE-】** to adjust parameter.

## RELOAD DEFAULT SETTING

Single user drum kit is restored to factory settings

Press **【SETUP】** to enter SETTING menu, press **【DOWN】** to select DEFAULT SETTING, then press **【SETUP】** to enter DEFAULT SETTING menu.

2. You can also eliminate this problem of retriggering with the Mask Time setting. Mask Time does not detect trigger signals if they occur within the specified amount of time after the previous trigger signal was received. Retrigger Cancel detects the attenuation of the trigger signal level, and triggers the sound after internally determining which trigger signals were actually generated when the head was struck, while weeding out the other false trigger signals that need not trigger a sound.

## EFFECT SETTING

### EQ setting

Press **【SETUP】** to enter SETTING menu, and press **【DOWN】** to select EFFECT, then press **【SETUP】** to enter EFFECT menu.

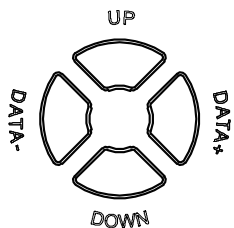
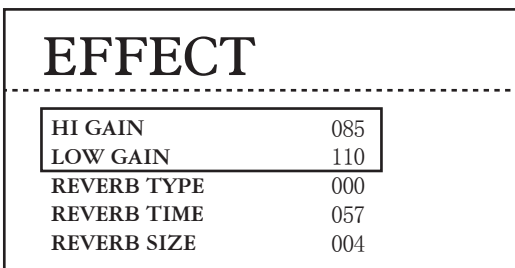
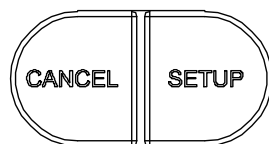
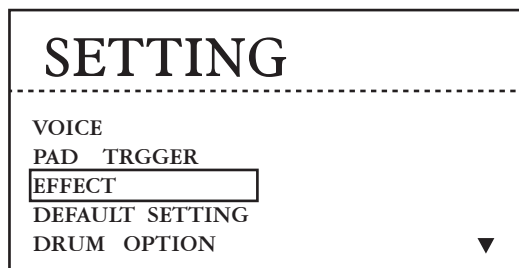

**HI GAIN:** Adjust the volume gain in the high frequency range. Press **【DATE+】** or **【DATE-】** to adjust the parameter.

**LOW GAIN:** Adjust the volume gain in the low frequency range. Press **【DATE+】** or **【DATE-】** to adjust the parameter.

### Adjusting pad curve

**VEL CURVE:** Refers to the corresponding relationship between percussion strength and volume. By adjusting the parameters, it can make the percussion feel more comfortable and natural. Users can set the parameters according to their percussion habits.

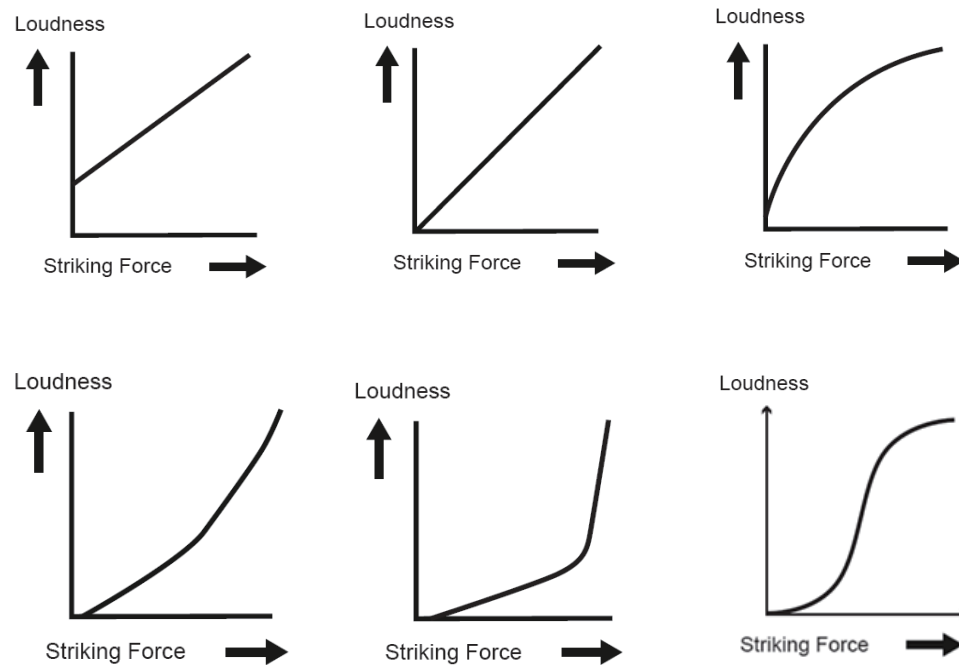

**CURVE 1:** Small dynamic response. Select this curve and it delivers high but stable volume.

**CURVE 2:** The standard setting to deliver natural signal.

**CURVE 3:** Compared to CURVE 2, low striking force causes big volume change.

**CURVE 4:** Compared to CURVE 2, comparatively high striking force causes comparatively big volume change.

**CURVE 5:** Compared to CURVE 2, comparatively high striking force causes very big volume change.

**CURVE 6:** The striking force causes extreme volume change.

### Adjust pad threshold

---

THRSHLD: the minimum force to trigger a pad signal.

Setting a high threshold (high value), the pad needs a strong force to generate a signal. This can avoid accidental response, e.g. other device or pad generating unnecessary signal.

Setting a low threshold (low value), the pad only needs a weak force to generate a signal.

### Eliminate pad crosstalk

---

CROSSTALK

When two pads are close, hitting one pad can cause the other pad to generate a signal. This crosstalk can be eliminated by setting a high parameter of the other pad. Note: If the crosstalk value is set too high, when two pads are played simultaneously the one that is struck less forcefully will not sound, so be careful and set this parameter to the minimum value required to prevent such crosstalk. In addition, when this parameter is set to 0, crosstalk suppression does not work.

### Adjust pad sensitivity

---

SENSITIVITY

You can adjust the sensitivity of the pads to accommodate your personal playing style. This allows you to have more dynamic control over the sound volume based on how hard you play.

Higher sensitivity allows the pad to produce a loud volume even when played softly. Lower sensitivity will keep the pad producing a low volume even when played strongly.

### Adjust triggering mask time

---

MASKTIME

This setting allows you to prevent double trigger. The adjustment of this parameter is used to adjust the time interval when the drum pad is triggered to scan. When the MASK TIME value is small, the drum pad is sensitive, but there may be repeated triggering. At this time, the MASK value should be appropriately increased.

When playing a kick trigger the beater can bounce back and hit the head a second time immediately after the intended note. This causes a single hit to "double trigger" (two sounds instead of one). The Mask Time setting helps to prevent this. Once a pad has been hit, any additional trigger signals occurring within the specified "Mask Time" will be ignored.

Adjust the value of "Mask Time" when playing the drum pad: When using a kick trigger, try to let the beater bounce back and hit the head very quickly, then raise the "Mask Time" value until there are no more sounds made by the beater rebound.

Note:

1. When set to a high value, it will be difficult to play very quickly. Set this to as low a value as you can
2. If two or more sounds are being produced when you strike the head just once, then adjust Retrig Cancel.

### Adjust signal attenuation

---

RETRGCANCEL

This setting allows you to prevent re-trigger.

Important if you are using acoustic drum triggers. Such triggers can produce altered waveforms, which may also cause inadvertent sounding at Point A in the following figure ( Re-trigger) .

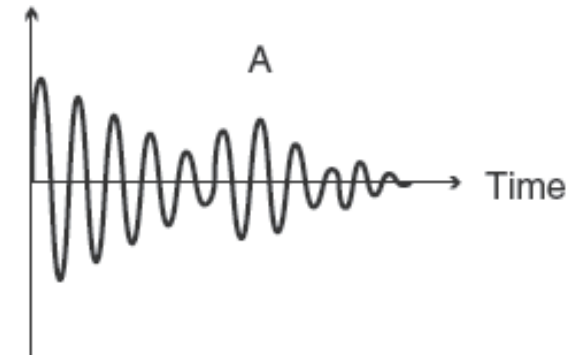

This occurs in particular at the decaying edge of the waveform. Retrigger Cancel detects such distortion in and prevents retriggering from occurring.

While repeatedly striking the pad, raise the "Retrig Cancel" value until retriggering no longer occurs.

Notes:

1. Although setting this to a high value prevents retriggering, it then becomes easy for sounds to be omitted when the drums are played fast (roll etc.). Set this to the lowest value possible while still ensuring that there is no retriggering